

00:00
1 1/4
1 1/4
1 1/4
FRIDN
RAPIDO

E9 Med

↓
ESC

○
START / STOP / DOOR

↑
ENTER

MED
E9



INDEX

Safe sterilisation, available for everyone.	05
• MODULAR STRUCTURE	10
Simply, everything you need.	07
• COOLING SYSTEM	10
Sterilisation cycles	08
Accessories	09
Technical insight	10
Technical specifications	11

Euronda

For you who love to surround yourself with beautiful things,
even when you're working. For you who hate complications.

For you who put safety before everything else.

For you who love well made things that last over time.

For you who want only the best...





EURONDA

PRION
RAPIDO

ESC START/STOP/DOOR ENTER

MED
ES

Safe sterilisation, available for everyone.

The E9 Med is the epitome of easy and user-friendly safety, available for everyone. Easy because of the Process Controller that assists you in the daily running of the autoclave and informs you when it is time for a scheduled maintenance check. User-friendly because of the blue display that keeps you up to date on every operation thanks to the clear and convenient interactive menu. Safe because it guarantees Class B sterilisation, completely conforming to EN 13060 standard requirements. E9 Med perfectly sterilises all packaged instruments (solid, hollow and porous) in a completely safe environment. In the version with the Instant Steam Generator, the E9 Med's performance in producing steam is guaranteed to be even better, helping to make the E9 Med the best within its price range.

➔ Focus on the topic
- **MODULAR STRUCTURE**
page 10

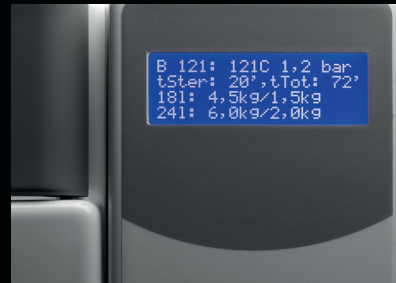



→ 134
134 PRION
121
134 RAPIDO

↓ ESC ○ START/STOP/DOOR ↑ ENTER

MED
ES

USED WATER

CLEAN WATER

Simply, everything you need.

E9 Med has all the characteristics to make your job convenient and efficient in every aspect. Like every Euronda autoclave, the E9 Med can also be inspected and cleaned directly by the user, without requiring the assistance of a specialist. The internal thermal paper printer records all the data from every sterilisation cycle (result, date and user) and the optional E-Memory device can store up to 48,000 tests and cycles, which are easily traceable and transferable to a computer. E9 Med is an autoclave intended to be reliable and long-lasting, thanks also to the built-in air-water separator that reduces the strain on the vacuum pump, thereby extending the machine's working life.

● Focus on the topic
➔ - **COOLING SYSTEM**
page 10



STERILISATION CYCLES

B 134

SOLID, POROUS AND HOLLOW,
WRAPPED AND UNWRAPPED

B 134 PRION

PRION CYCLE FOR WRAPPED AND
UNWRAPPED SOLID, POROUS
AND HOLLOW

B 121

SOLID, POROUS AND HOLLOW,
WRAPPED AND UNWRAPPED.
PARTICULARLY INDICATED
FOR PLASTICS, TURBINES AND
HANDPIECES

B 134 ⚡

RAPID CYCLE FOR WRAPPED AND
UNWRAPPED SOLID, POROUS
AND HOLLOW. FOR 1 TRAY
INSTRUMENTS

B 134 PRION ⚡

RAPID PRION CYCLE FOR
WRAPPED AND UNWRAPPED
SOLID, POROUS AND HOLLOW.
FOR 1 TRAY INSTRUMENTS

18 LITRES

TEMPERATURE	135,5° C	135,5° C	122,5° C	135,5° C	135,5° C
PRESSURE	2,16 bar	2,16 bar	1,16 bar	2,16 bar	2,16 bar
STERILISATION PHASE TIME	4'	18'	20'	3'30"	18'
DRYING PHASE TIME	15'	15'	15'	5'	5'
MAXIMUM SOLID/POROUS LOAD	4,5 kg / 1,5 kg	4,5 kg / 1,5 kg	4,5 kg / 1,5 kg	0,6 kg / 0,2 kg	0,6 kg / 0,2 kg
TOTAL STANDARD LOAD TIME*	42'	56'	58'	33'	47'

24 LITRES

TEMPERATURE	135,5° C	135,5° C	122,5° C	135,5° C	135,5° C
PRESSURE	2,16 bar	2,16 bar	1,16 bar	2,16 bar	2,16 bar
STERILISATION PHASE TIME	4'	18'	20'	3'30"	18'
DRYING PHASE TIME	15'	15'	15'	5'	5'
MAXIMUM SOLID/POROUS LOAD	6 kg / 2 kg	6 kg / 2 kg	6 kg / 2 kg	0,6 kg / 0,2 kg	0,6 kg / 0,2 kg
TOTAL STANDARD LOAD TIME*	41'	55'	54'	32'	46'

18 LITRES STEAM GENERATOR

TOTAL STANDARD LOAD TIME*	32'	49'	45'	28'	45'
---------------------------	-----	-----	-----	-----	-----

24 LITRES STEAM GENERATOR

TOTAL STANDARD LOAD TIME*	32'	49'	45'	28'	45'
---------------------------	-----	-----	-----	-----	-----

The times are understood to be without the pre-heating and dry phase. All times depend on the load and power supply.

ACCESSORIES



AQUAFILTER

DEVICE THAT PRODUCES DEIONISED WATER FOR THE AUTOCLAVE AND OTHER PIECES OF EQUIPMENT IN A DENTAL SURGERY IN COMPLIANCE WITH THE EN13060 STANDARD (<math>< 15 \mu\text{S}/\text{CM}</math>). EVEN MORE PRACTICAL AQUAFILTER CAN REST ON THE WORKTOP OR INSIDE A CABINET, OR IT CAN BE WALL-MOUNTED OR INSTALLED ON THE AUTOCLAVE. AN INDICATOR LIGHT SHOWS THE WATER CONDUCTIVITY LEVEL ALLOWING YOU TO SEE WHEN IT'S TIME TO REPLACE THE RESINS AT A GLANCE. THE CONTROL ON THE FRONT ALLOWS YOU TO SUPPLY WATER MANUALLY. AQUAFILTER DEIONISES AN AVERAGE OF 1 LITRE OF WATER PER MINUTE. IT CAN BE EQUIPPED WITH AN AUTOMATIC SHUTOFF DEVICE.

- OVERALL DIMENSIONS: 390X455X145 MM (LXHXD)
- WEIGHT: 8,8 KG (WITH FULL VESSELS)



STERILISATION TEST

TO GUARANTEE THAT THE STERILISATION CYCLE HAS BEEN CORRECTLY CARRIED OUT, EURONDA RECOMMENDS YOU RUN THE CHECK TEST TO VERIFY:

- THE STEAM PENETRATION CAPACITY DURING HOLLOW LOADS (HELIX, DAILY) POROUS LOADS (BOWIE & DICK, MONTHLY) AND THE MAINTAINING OF PRESSURE VESSEL PERFORMANCE (VACUUM, DAILY)
- STEAM PENETRATION CAPACITY DURING POROUS LOADS (BOWIE & DICK, MONTHLY)
- MAINTAINING OF PRESSURE VESSEL AND HYDRAULIC CIRCUIT PRESSURE (VACUUM, DAILY).



AQUADIST

WATER DISTILLER THAT BOILS WATER AND CONDENSES THE STEAM TO OBTAIN DISTILLED WATER. IT DISTILLS 0.7 LITRES OF WATER PER HOUR. 4 LITRES CAPACITY. IT PASSES ALL SAFETY TESTS, COMPLYING WITH ALL ELECTROMAGNETIC COMPATIBILITY STANDARD (2004/108/CE) AND LOW VOLTAGE STANDARD (2006/95/CE) REQUIREMENTS.



E-MEMORY

EXTERNAL MEMORY FOR THE STORAGE, THE MANAGEMENT AND THE EASY TRACEABILITY OF 48.000 STERILISATION CYCLES AND CONTROL TESTS. THE DATA OF 9 DIFFERENT USERS MAY BE SETTED AND TRANSFERRED ON E9 AND PC. THANKS TO ITS UNIQUE SOFTWARE, THEY MAY BE PRINTED OR SENT BY EMAIL. THE REPORT MAY BE PERSONALIZED WITH GRAPHIC LOGO AND PERSONAL DATA OF THE STUDIO.

TECHNICAL INSIGHT

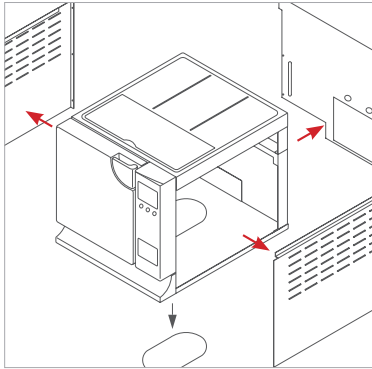

MODULAR STRUCTURE

THE WATER TANKS CAN BE COMPLETELY OPENED AND INSPECTED; THE LATERAL PANELS, MADE IN LIGHT MATERIALS, ARE EQUIPPED BY AN EASY AN SEPARATE LATCH; THE REAR PANEL IS INDEPENDENT AND THE BASE WITH A SEPARATE OPENING FOR THE INSPECTIONABILITY OF THE STEAM GENERATOR GUARANTEES AN EASY AND QUICK ACCESS FOR THE MAINTENANCE OPERATIONS.

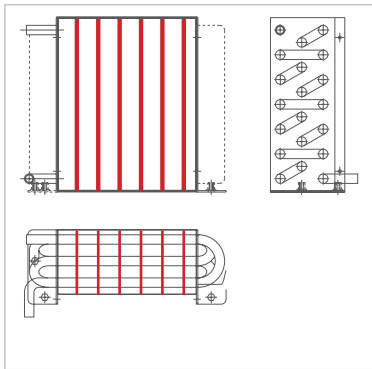

COOLING SYSTEM

THE CONDENSATION SYSTEM MOUNTED ON THE REAR OF THE E9 MED AND COOLED BY A FAN KEEPS THE CONDENSATION EXITING THE CHAMBER IN ITS INTERIOR, COOLING IT AND OBTAINS THE THERMODYNAMIC VACUUM.

TECHNICAL SPECIFICATIONS

OVERALL REQUIRED SPACE

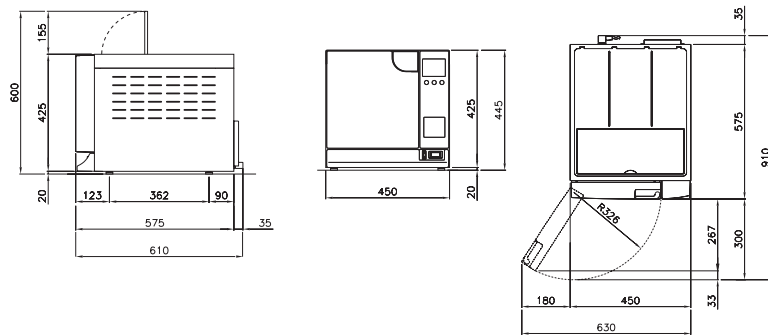

TECHNICAL DATA

	E9 MED - 18 L	E9 MED - 24 L
OVERALL DIMENSIONS	450 x 445 x 610 mm (L x H x D)	
WEIGHT (machine empty with basket and trays)	40 kg	42 kg
POWER SUPPLY	230 V 50/60 Hz	
ABSORBED CURRENT (output)	1400 W 6.1 A	1800 W 7.8 A
OPERATING TEMPERATURE	+5 - +40°C	
OPERATING ALTITUDE (leaving the loading cap free)	≤ 2000 m a.m.s.l	
MINIMUM DEPTH OF THE SUPPORT SURFACE	600 mm	
MINIMUM WIDTH OF THE SUPPORT SURFACE	460 mm	
NOISE LEVEL	< 50 dB	
WEIGHT PER SUPPORT AREA (tank full and chamber with maximum load)	3,07 kg/cm ² (301210N/m ²)	3,21 kg/cm ² (315384N/m ²)
OPERATING RANGE	Indoor use Relative humidity 85% Maximum line-voltage deviation ±10% Installation category II Pollution level 2	
CHAMBER MEASUREMENTS AND VOLUME	250x340 mm ØxD	250x440 mm ØxD
DIMENSION AND VOLUME	180x282x160 mm LxDxH	180x382x160 mm LxDxH
WATER CONSUMPTION VOLUME	0,6 litres	
TANK CAPACITY (clean water and used water)	4 litres	
	E9 MED STEAM GENERATOR - 18 L	E9 MED STEAM GENERATOR - 24 L
WEIGHT (machine empty with basket and trays)	42 kg	44 kg
ABSORBED CURRENT (output)	2300 W 10 A	

USEFUL SPACE

18 LITRES

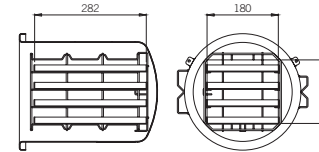

18 LITRES STEAM GENERATOR

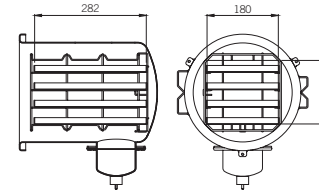

24 LITRES

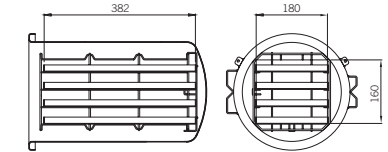

24 LITRES STEAM GENERATOR

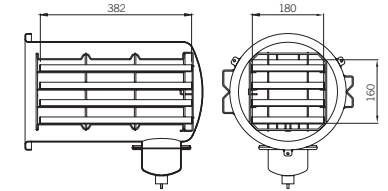

SAFETY DEVICES

- Short-circuit protections
- Overheating protections
- Overpressure protection
- Accidental door opening protections
- Process appraisal system
- Real-time self-diagnostic system

DOCUMENTATION

- User Manual
- Declaration of conformity Chamber
- Declaration of conformity autoclave
- Warranty Certificate
- Installation chart
- Servicing handbook

COMPLIANCE WITH HARMONISED STANDARDS

- EN 13060
- EN ISO 14971
- EN 61010-1
- EN 61010-2-040
- EN 61326
- EN 13445

CERTIFICATION INFORMATION

- E9 Med Autoclave compliant with Directive 93/42/EC and addenda.
- Class IIb device
- Chamber compliant with PED Directive 97/23/EC
- Company certification: ISO 9001 ISO 13485



Headquarters: EURONDA SPA
36030 Montecchio Precalcino (Vicenza) Italy
Via dell'Artigianato, 7
tel. +39 0445 329811 - fax +39 0445 865246
info@euronda.com - www.euronda.it Eurc  a SPA

Deutschland: EURONDA DEUTSCHLAND GMBH
48341 Altenberge
Siemensstraße, 46
tel. +49 2505 9389 0 - fax +49 2505 9389 29
info@euronda.de - www.euronda.de

España: EURONDA SPA
IDENTYD - Av. Cabezo de Torres, 4, local
30007 Murcia - ESPAÑA
Atención al cliente: 900102034
info@euronda.es - www.euronda.es

France: EURONDA FRANCE
ZAC Les Vallées - Avenue de Bruxelles
60110 Amblainville
tél. +33 (0)3.44.06.69.70 - fax +33 (0)3.44.02.03.89
info@euronda.fr - www.euronda.fr

Russia: Proteco ZAO
196128, St. Petersburg
5/2 Varshavskaya str.
tel./fax +7 (812) 635 88 90
info@protecodent.ru - www.protecodent.ru