

PRO 4K

USER GUIDE

Index

Index.....	3
Specification.....	5
CHAPTER 1 Asiga PRO 4K at a Glance.....	6
Principle of Operation.....	8
Native and 4K Resolution.....	10
CHAPTER 2 Getting Started.....	12
Unpacking.....	12
Location.....	12
Power On.....	12
Choose your Language.....	13
Enable the machine with the warranty code.....	14
Install Build Platform.....	15
Zero Position Calibration.....	15
Zero Position Encoders.....	20
Refresh Projector Motor Positions.....	21
Network Connection.....	21
Ethernet Setup.....	22
Wireless Setup.....	22
Wireless Direct Setup.....	22
Install Composer Software.....	23
CHAPTER 3 Preparing a Build.....	24
CHAPTER 4 Starting a Build.....	25
Installing the Vat.....	25
Add Resin to the Vat.....	26
Clean the Vat Bottom.....	26
Set the Chamber Temperature.....	28
Starting the Build.....	29
Stopping and Pausing the Build.....	29
CHAPTER 5 Web Interface.....	30
Accessing the Web Interface.....	30
Build Queue Tab.....	30
Front Panel Tab.....	31
Settings Tab.....	32
System Information Tab.....	33
Update Firmware Tab.....	35
Support Tab.....	35
Restricted Mode.....	36
Policy Editor.....	37
CHAPTER 6 Post-processing Parts.....	40
Removing Parts from the Build Platform.....	40
Washing Parts.....	40
Post-Curing Parts.....	41
CHAPTER 7 Maintenance and Calibration.....	43
Zero Position.....	43
Focus.....	43
LED.....	44
Sensors.....	44
Spot Timer.....	45
Viscosity Analyzer.....	46
Clear User Data.....	48
Test Parallelism.....	48

Show During Build.....	52
CHAPTER 8 Service.....	54
Bottom Limit.....	54
Film Thickness.....	54
Calibrate Radiometer.....	55
Normalize Radiometer.....	57
Calibrate Position Encoders.....	59
Calibrate Deflection.....	67
Detect Zero Position.....	69
Projector Calibration.....	70
Touch Screen.....	71

Specification

Product specification	PRO 4K65	PRO 4K80
Build Volume X, Y, Z	176 × 99 × 200 mm 6.94 × 3.9 × 7.87 inches	217 × 122 × 200 mm 8.54 × 4.8 × 7.87 inches
Pixel Resolution	65µm	80µm
Technology	DLP	DLP
LED Wavelength	385nm (high power UV LED) or 405nm	385nm (high power UV LED) or 405nm
Material Compatibility	Asiga materials, 100% Open Material System – use any suitable third party materials	
Software	Asiga Composer software	
File Inputs	STL, SLC, PLY, STM (Asiga Stomp file format)	
Network Compatibility	Wifi, Wireless Direct, Ethernet	
Power Requirements	90-264VAC, 50/60Hz, 600Watts, (100V – 6Amp Max. 240V – 2.5Amp)	
System Sizing	465 x 420 x 1370mm / 75 kg 18.3 x 16.5 x 53.9 inches / 165 lb	
Packed Sizing	910 x 640 x 1560mm / 100 kg 35.8 x 25.1 x 61.4 inches / 220 lb	
Warranty	12 months manufacturer's warranty	
Technical Support	Unlimited lifetime technical support included	
Bundle Includes	3D printer, Composer software, 1kg Asiga material, 1L build tray, Asiga Flash post-curing chamber, calibration toolkit	

CHAPTER 1

Asiga PRO 4K at a Glance

These diagrams illustrate the main user controls on the PRO 4K.

FRONT VIEW

REAR VIEW

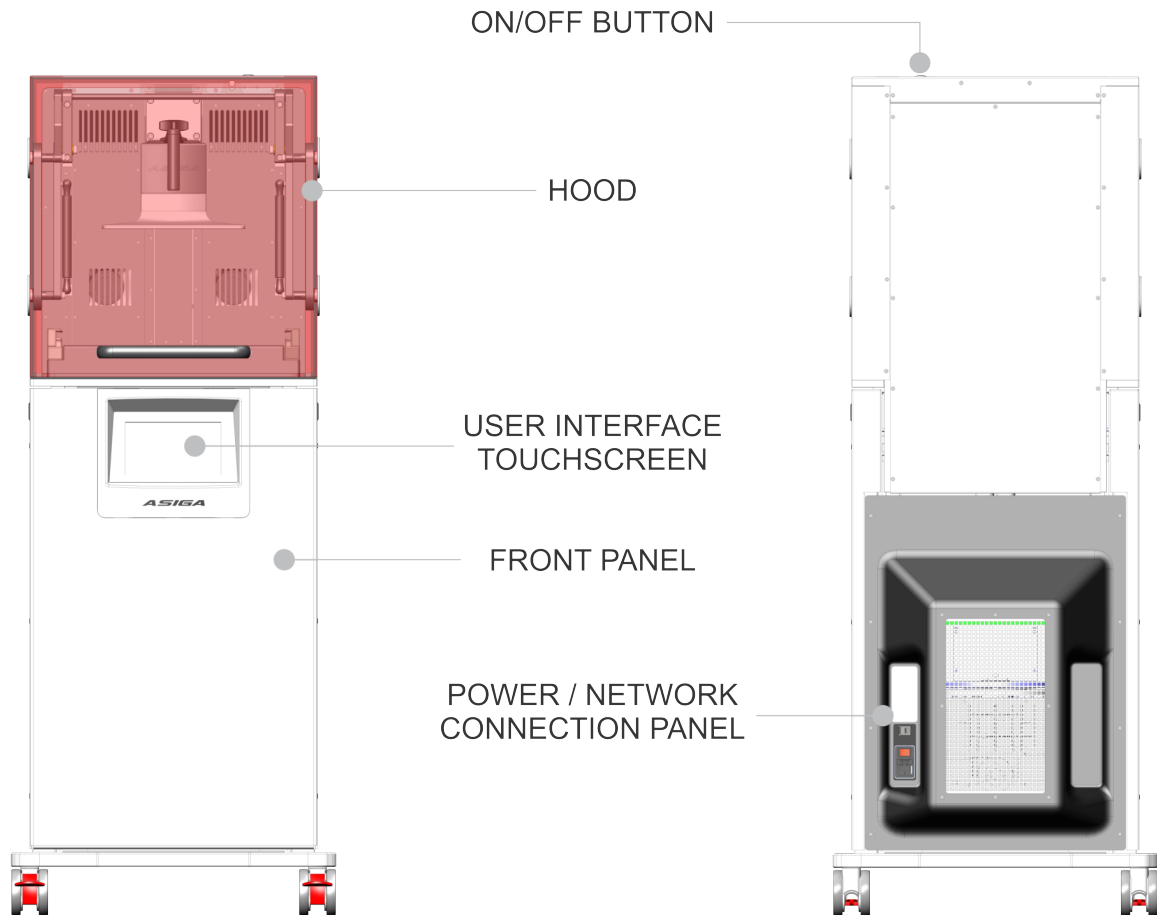

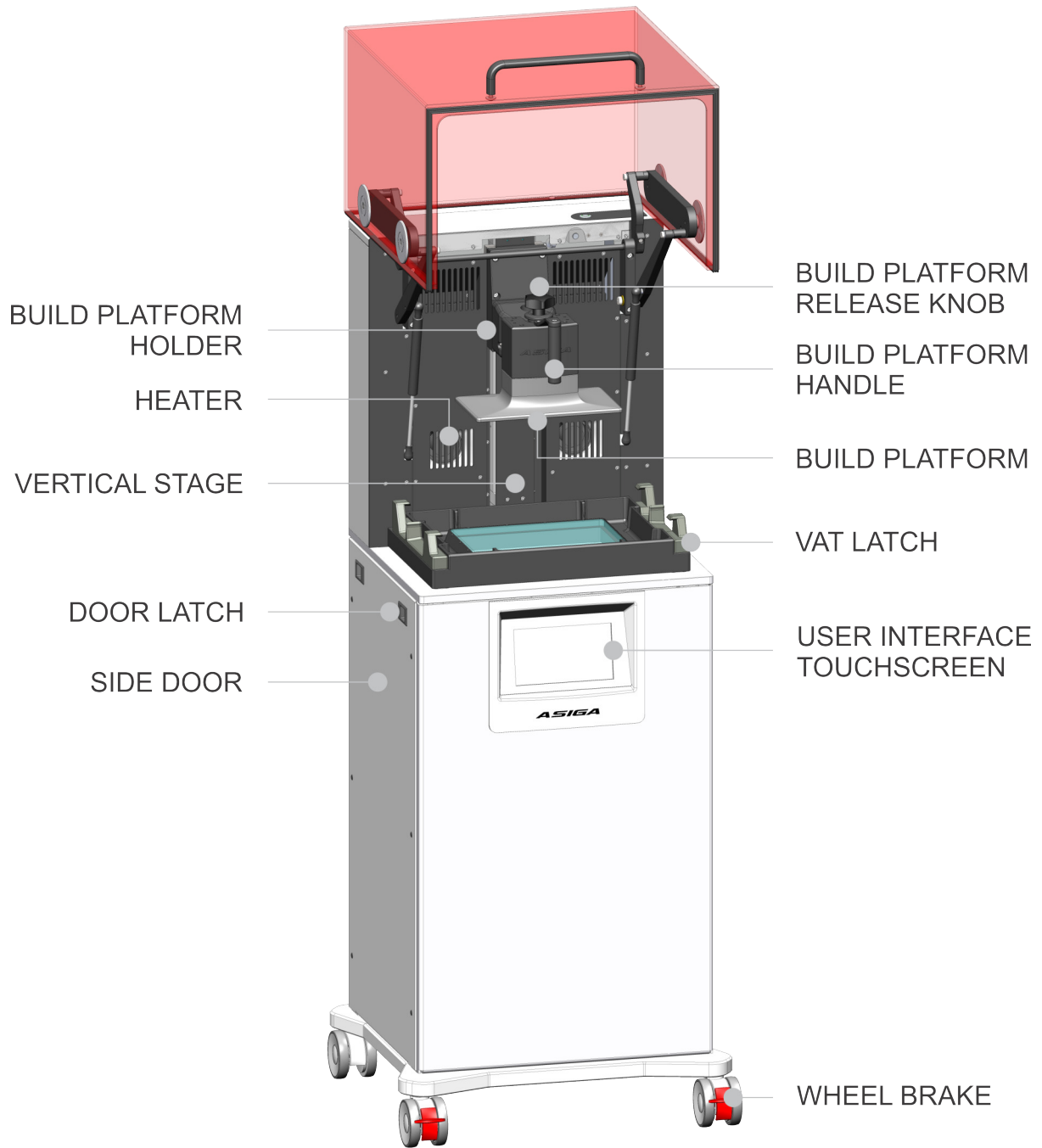

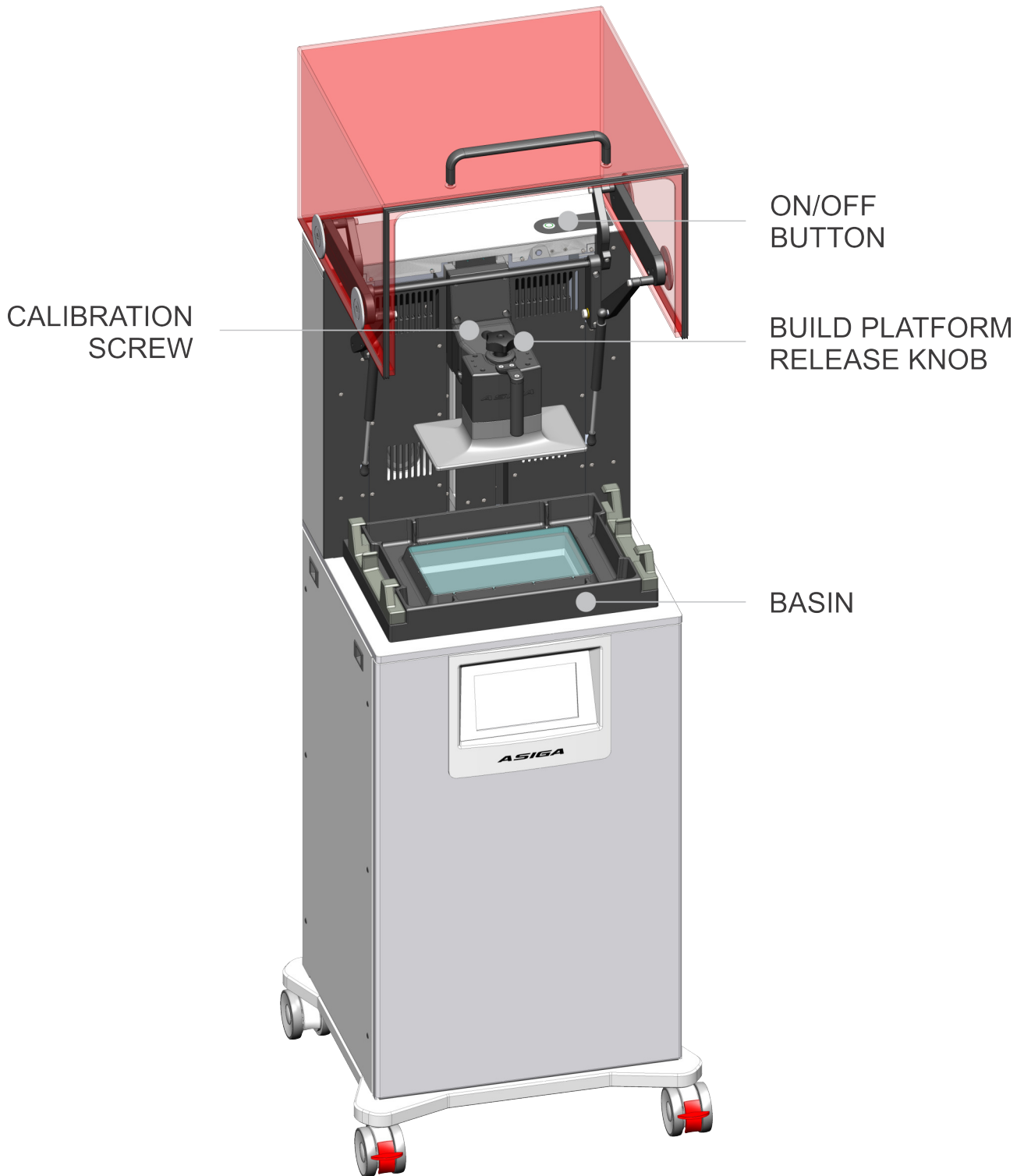

Principle of Operation

The PRO 4K is a 3D printer which builds objects from CAD data. The objects are built from photopolymer resins which are liquid chemicals that can be solidified by exposure to light. A physical model is built by solidifying successive layers of photopolymer against each other. This process is called “stereolithography”.

The PRO 4K build process employs a unique feature which is referred to as the Smart Positioning System (SPS). The SPS utilizes an array of position encoders which detect when a layer of correct thickness is formed. The process works as follows:

1. The model under construction is positioned above the vat of photopolymer. The vat bottom is made from a flexible transparent Teflon film which is supported by a glass plate.

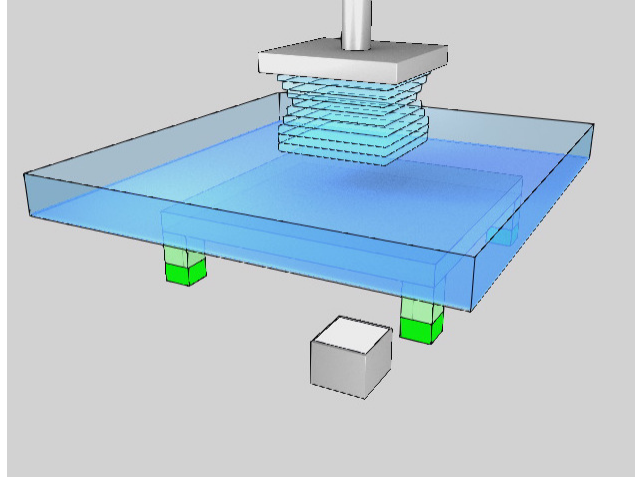

2. The model is moved downwards to one layer-thickness above the bottom of the vat. The movement squeezes photopolymer resin out from the gap between the model and the Teflon film. Viscous forces oppose the motion, resulting in mechanical deflection of the apparatus.

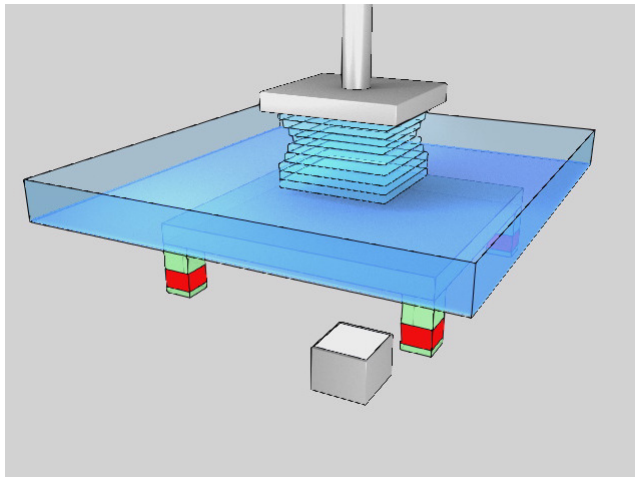

3. Four position encoders at each corner of the glass plate precisely monitor the mechanical deflection between the glass plate and the model under construction. The process monitors the deflection until it is relieved.

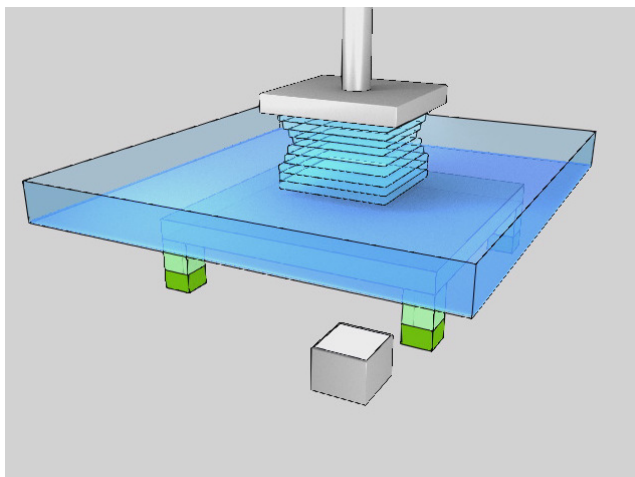

4. A cross-sectional image of the object being constructed is projected onto the underside of the vat film, causing photopolymer to harden in the shape of the image.

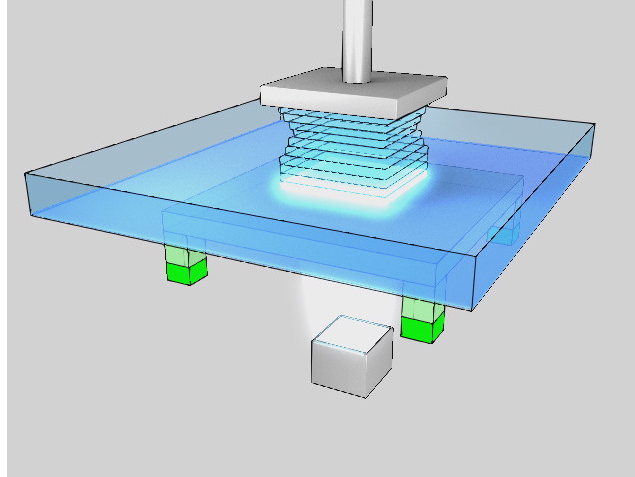

5. The model is lifted out of the vat to separate it from the vat film.

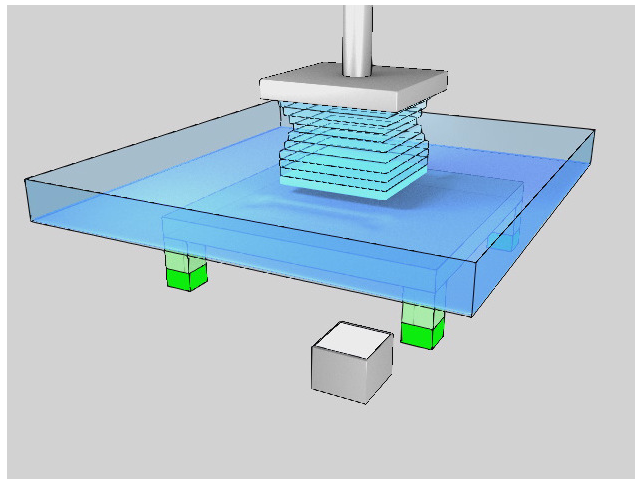

6. The process is repeated until the model has finished building.

The SPS process actively forms layers of precise thickness regardless of the cross-sectional area of the model or the viscous behavior of the photopolymer resin. As a result, models of high fidelity are produced. The PRO 4K is ideal for direct manufacturing applications including medical prostheses and jewellery pattern production.

Native and 4K Resolution

The PRO 4K light engine is equipped with a DLP imaging chip having a 2716-by-1528 pixel array. The projected image can be spatially shifted at high frequency by a piezoelectric mechanism to produce a 3840-by-2160 pixel image. The effect simulates a 4K resolution image. Operating in this mode produces images and consequently 3D parts having smoother edges and resolution than produced in the native mode. However, the native pixel size is larger than the pixels of the 4K image, which means that some control is lost over the rendering process at the edges of the image contours. For this reason, the user has the option to switch off the piezoelectric mechanism and operate the light engine in native resolution mode, producing a 2712-by-1528 image. Note that the native resolution image does not use all the pixels present on the DLP chip.

The Settings menu has a 4K Mode toggle. If the toggle is turned on, the projector operates in 4K mode. If the toggle is off, the projector operates in Native Mode.

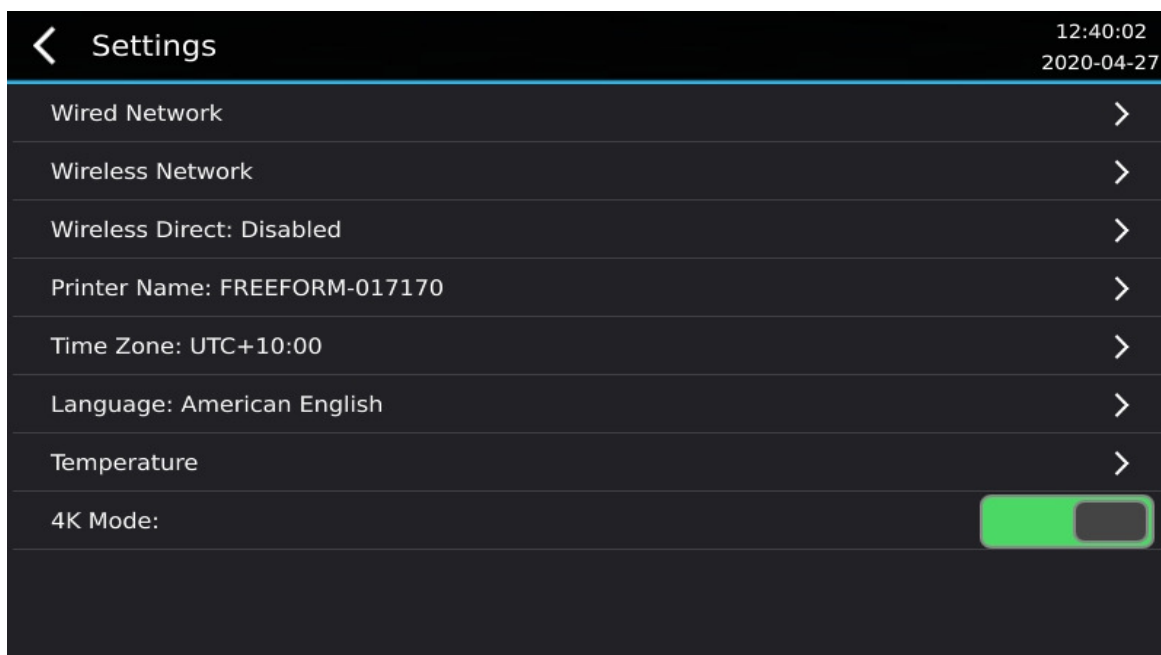

The 4K Mode should be changed, if required, prior to generating the build and sending it to the printer.

CHAPTER 2

Getting Started

Unpacking

Refer to the PRO 4K unpacking guide. This is supplied with the machine.

Note the markings on the side of the crate indicating which side is the door. Open the crate and use the door as a ramp to lower the printer from its pedestal to the ground. Note that accessories may be packed inside the crate.

Do not discard your crate. Put it in a safe place should you need to transport your PRO 4K machine for any reason.

Location

Ensure your PRO 4K is placed on level ground with access to mains electricity. Avoid direct sunlight as this will degrade material left in the machine. The ground top does not need to be perfectly level. Avoid contact with vibrating surfaces.

Power On

Plug the power supply cable into the AC power input at the rear of the machine. The power supply is designed for input between 100 – 240V AC single phase.

Turn on the PRO 4K machine by:

1. Flipping the power switch on the back of the machine to the ON position. You will see Standby Power LEDs on the back of the machine become illuminated.

IMPORTANT NOTE: TO SHUTDOWN THE MACHINE ALWAYS DO SO VIA THE USER TOUCH SCREEN DISPLAY. NEVER SHUTDOWN USING THE POWER SWITCH. TO POWER OFF YOU CAN USE THE FLIP SWITCH BUT ONLY AFTER THE MACHINE HAS BEEN SHUTDOWN VIA THE USER TOUCH SCREEN DISPLAY.

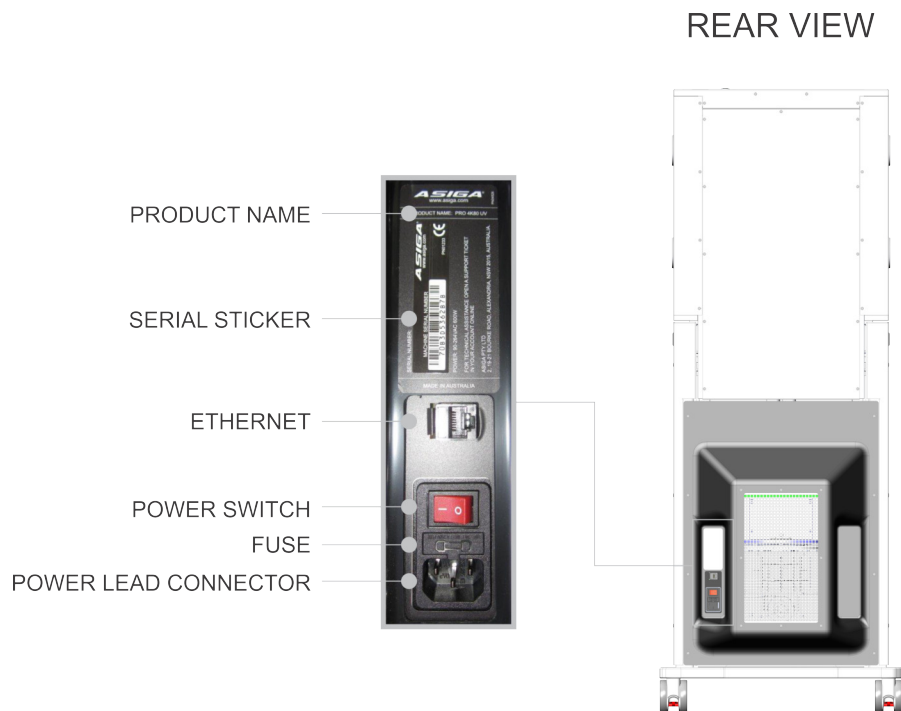

2. Press the ON/OFF button at the top right of the machine. The LCD screen at the front of the PRO 4K will turn on. Within 15 seconds the user interface will become active. The user interface is an interactive touch-screen LCD.

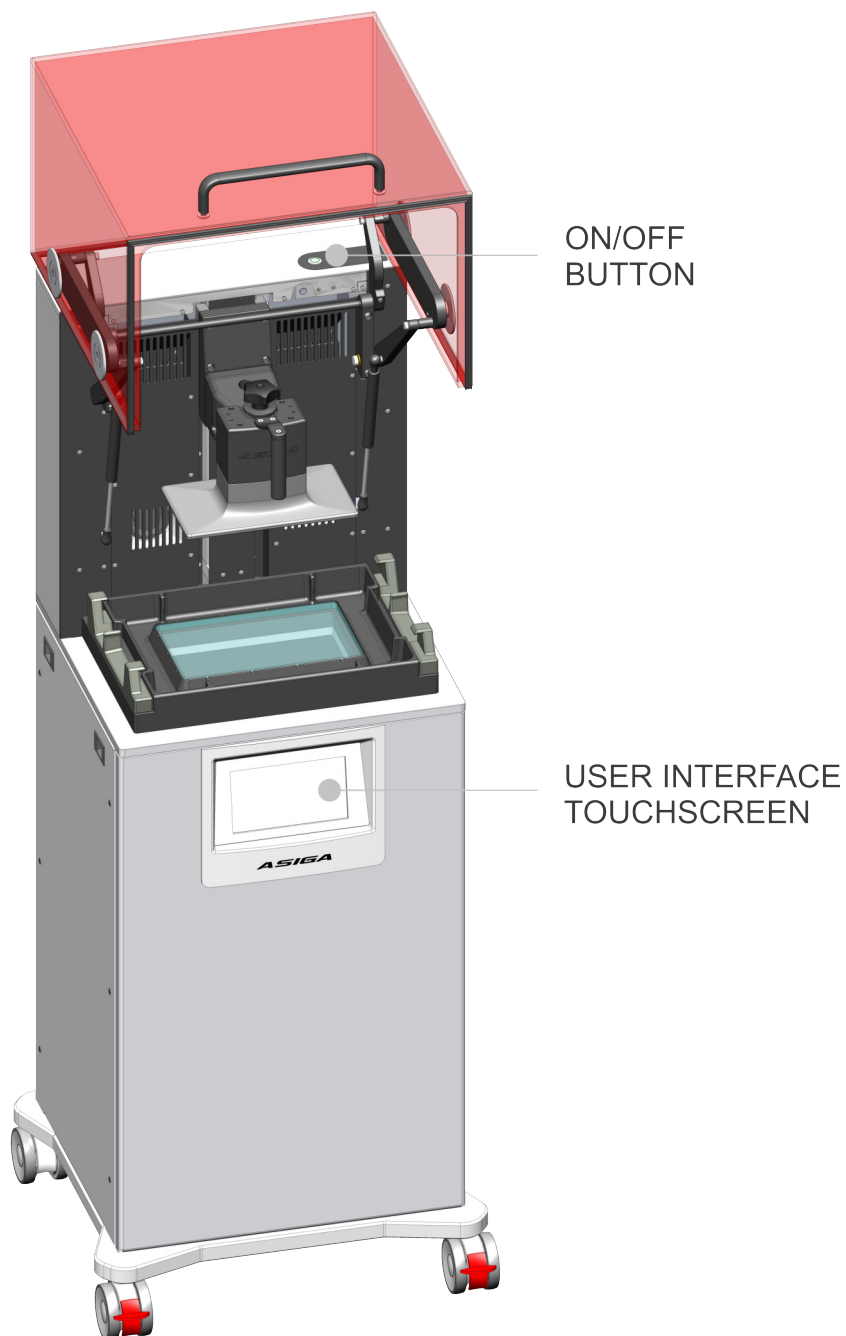

Choose your Language

Upon initial startup you will be given the option to select your language by scrolling through a list presented on the LCD screen.



If the machine has already been started, you can change the language in the menu:
Settings > Language.

Enable the machine with the warranty code

On first startup you will be presented with a screen to enter the warranty code.

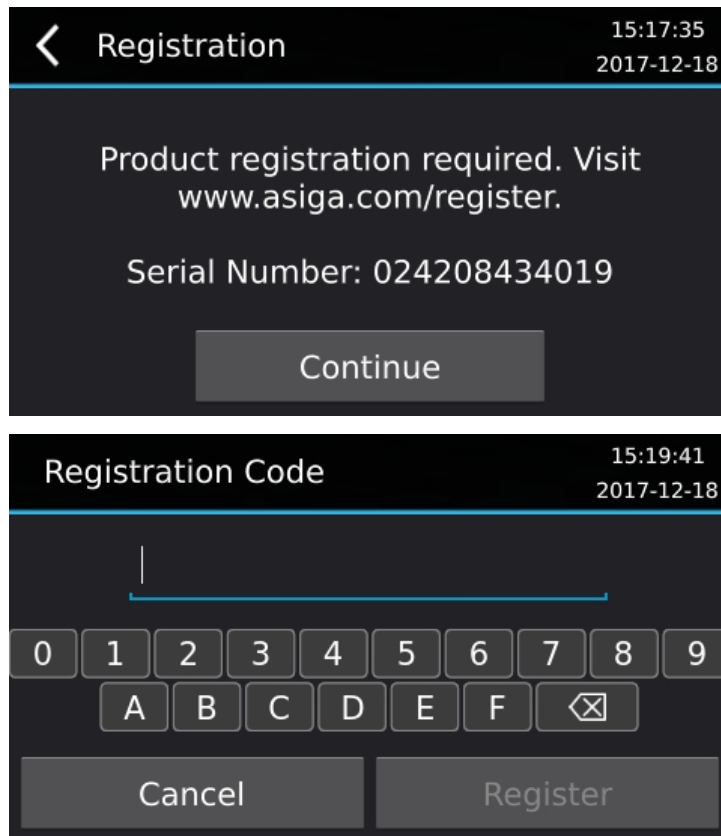

You can obtain your warranty code by visiting:

www.asiga.com/register

You will be requested to register an account. Once your account has been activated you will be directed to a screen where you can enter the serial number of your machine. The warranty code registers your machine with Asiga and commences the one year warranty on your system. Alternatively, your reseller may provide you with the warranty code.

You can operate the PRO 4K without entering the warranty code. However, you can only complete a maximum of ten builds. After this the warranty code needs to be entered to continue printing with the PRO 4K.

Install Build Platform

The PRO 4K vertical axis has a bracket for holding the build platform. Secure it in place by tightening the release knob.

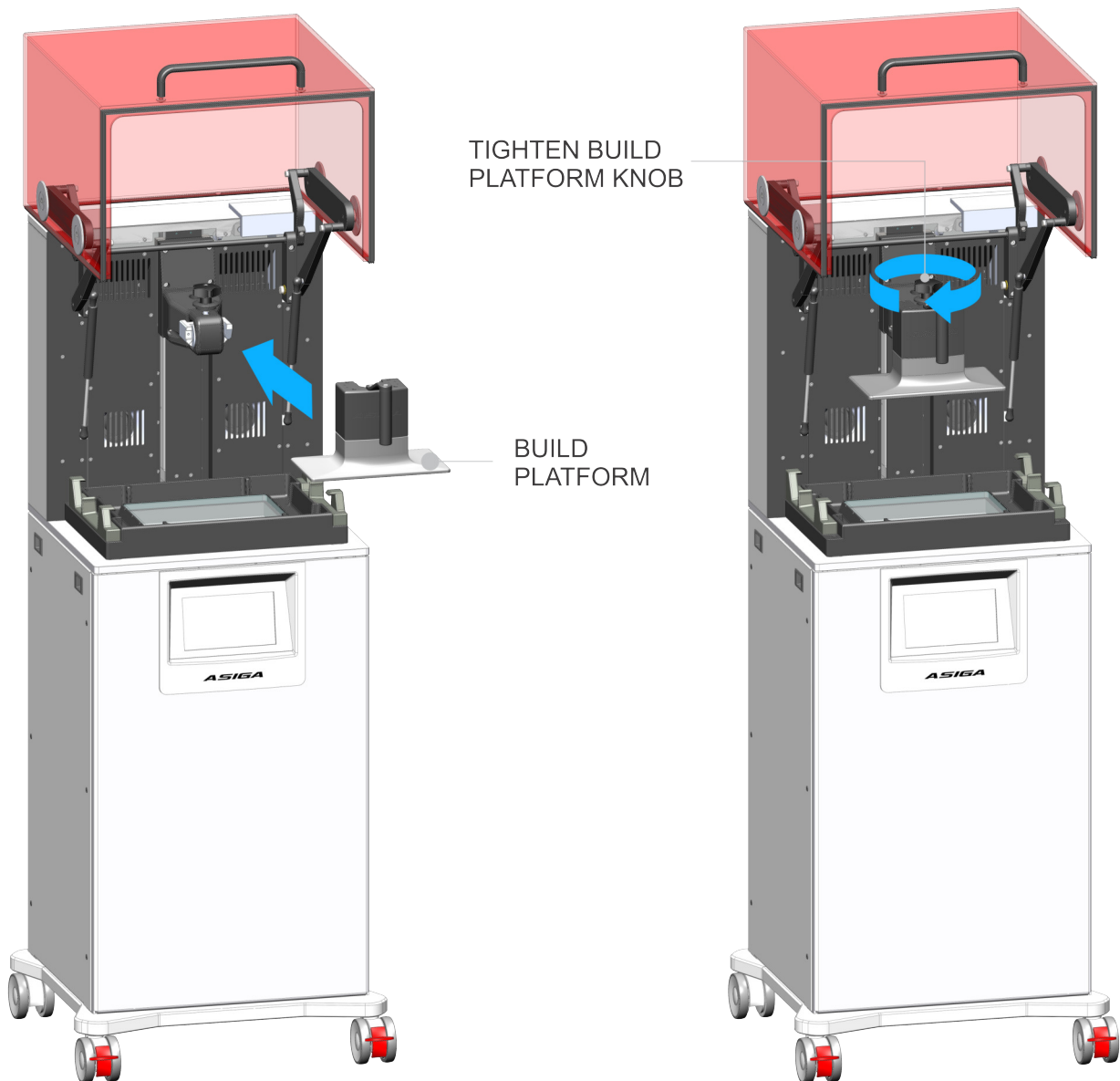

Zero Position Calibration

Note: a video demonstration of the zero position calibration procedure is included on the USB stick which ships with your machine.

Correct operation of the PRO 4K requires:

1. The build platform to be parallel to the glass window; and
2. The build platform to be in contact with the glass window when the vertical axis position is set to zero.

This is accomplished by performing the “zero position” calibration procedure.

The zero position calibration is done in the factory before the machine is shipped. However, it is recommended to recalibrate this position after the machine is transported or every few months. Poor zero calibration can result in models not attaching to the build platform.

To calibrate the zero position:

1. Install the build platform onto the vertical axis bracket.
2. Tighten the Build Platform Release Knob to secure the build platform in place.
3. Go to menu item Maintenance > Zero Position.

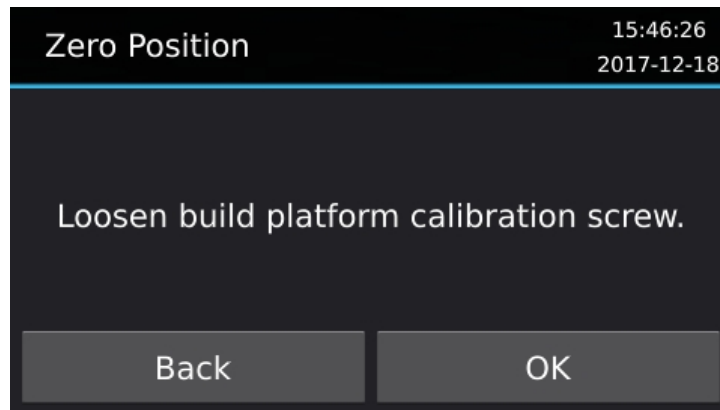

4. Loosen the build platform calibration screw. This can be done with the torque wrench tool for M8 hex screw which is included in the PRO 4K Calibration Tool Kit. When the screw is properly loosened, the build platform should be able to move freely up and down and rotate around the horizontal axes of the machine.

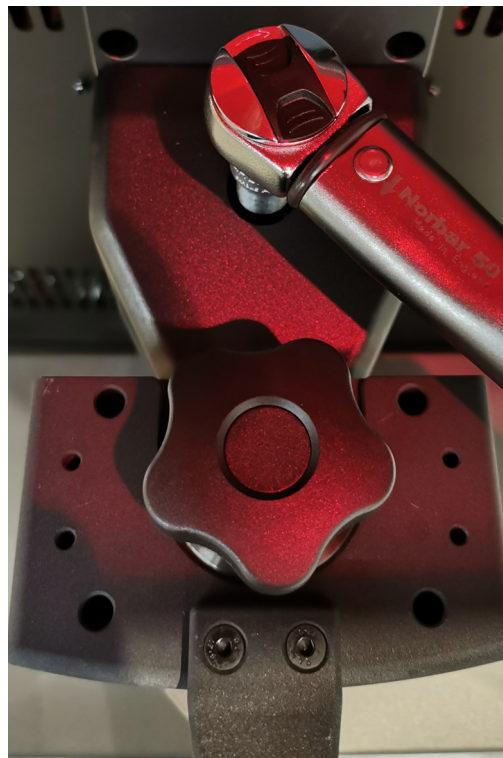

5. Loosen the small grub screw directly behind the knob with a 2.5mm allen key tool which is included in the PRO 4K Calibration Tool Kit.

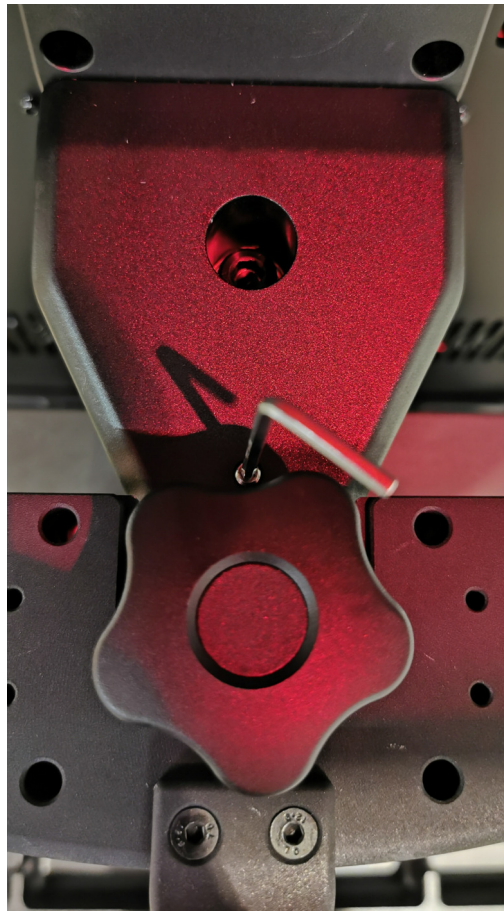

6. Press "OK".
7. Set the calibration plate thickness. A calibration plate is a spacer placed underneath the build platform, if required, whose thickness is subtracted by the printer software if used. Normally no calibration plate is required, so a value of 0.00 mm can be selected.

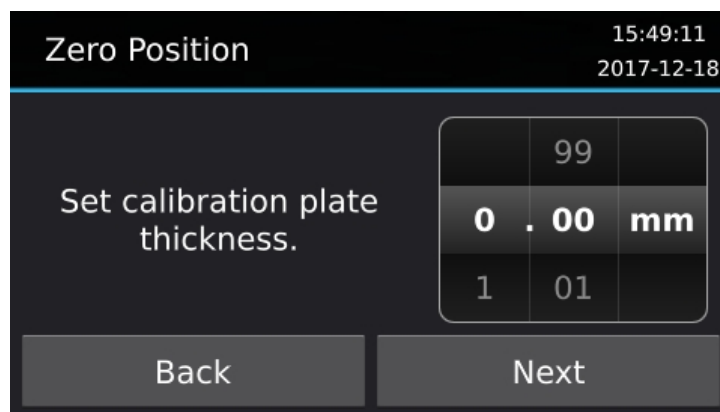

8. Press "Next".

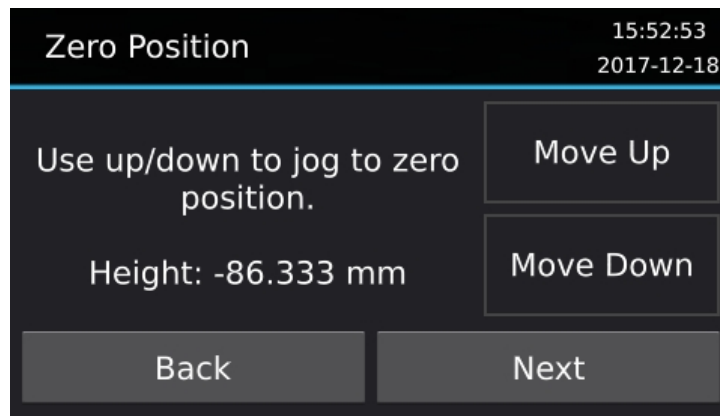

9. Use the “Move Up” and “Move Down” buttons to lower the build platform to the lowest position.

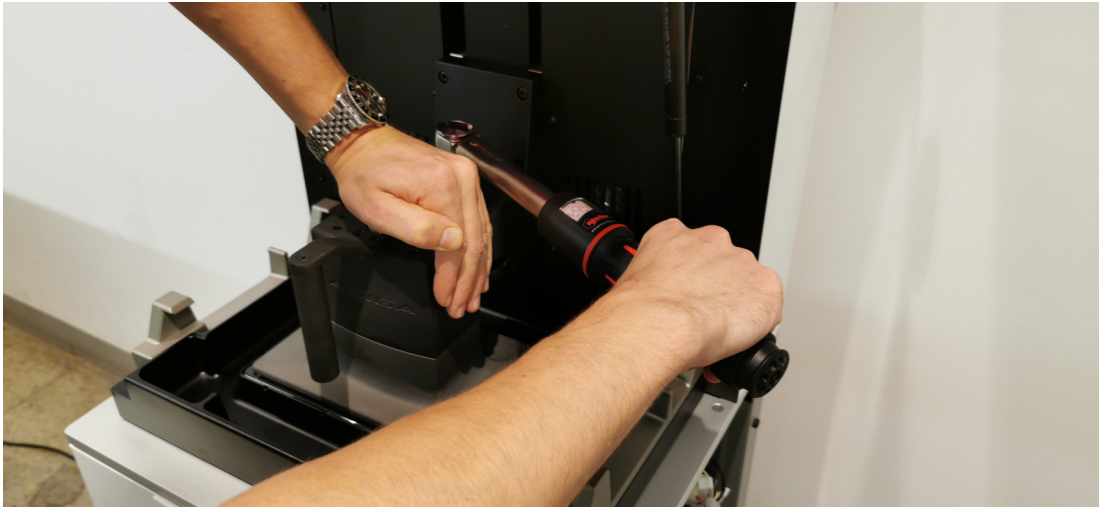

10. Press “Next”.
11. Confirm the new zero position by pressing “Yes”.

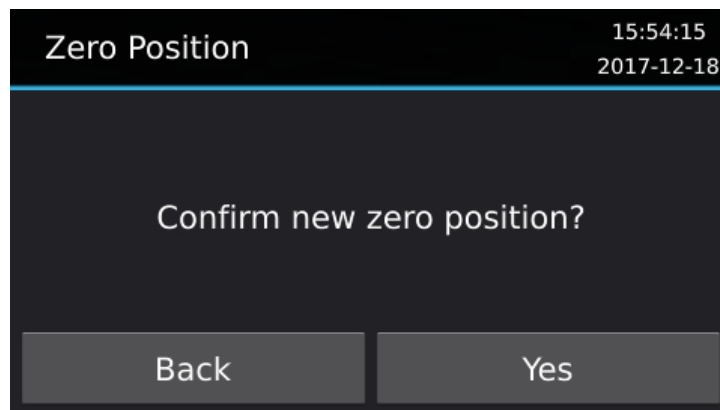

12. Gently push the build platform flat against the glass exposure plate. Ensure that the edges of the build platform are not resting on the metal rim around the glass exposure plate.
13. While still applying pressure, tighten the calibration screw with the M8 hex key.
NOTE: to prevent slippage of the joint you should apply sufficient torque when tightening the calibration screw whilst not overtightening. To apply the correct torque, use a 12.5Nm torque wrench.
14. Tighten the grub screw behind the knob.

15. Click “Done”.

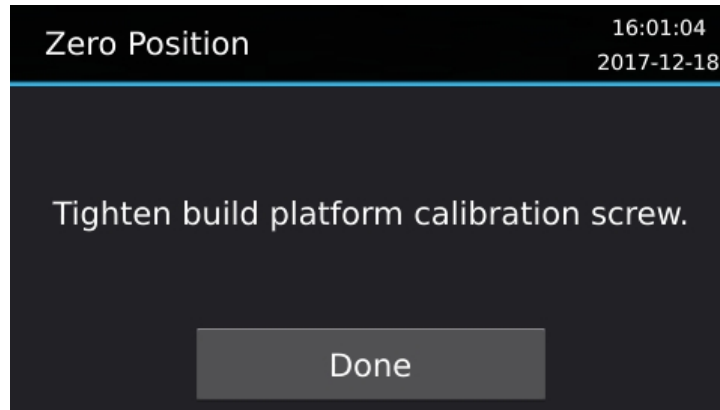

16. Detect the zero position. The feedback from the position encoders may be used to automatically detect the zero position of the build platform. To run the automatic detection process, click “Yes”.

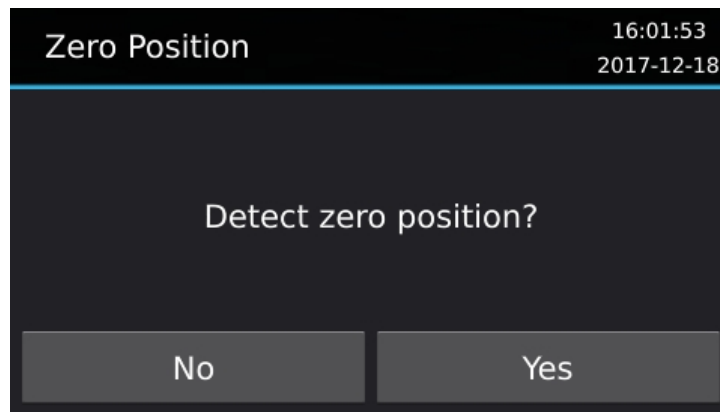

17. The following screen will be displayed:

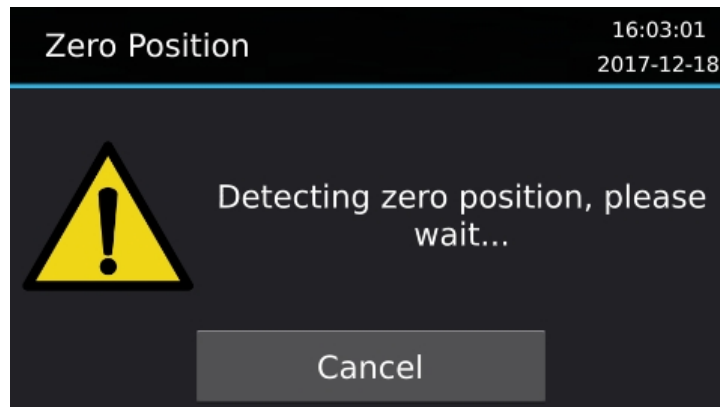

18. Pressing Cancel will stop the “detect zero position” process and skip to the “Home vertical axis?” screen.
19. After the process is bypassed or completed, click “Yes” to home the vertical axis or “No” to leave it at the current position.
20. If you have just received your new PRO 4K machine, the next step is to calibrate the position encoders. The position encoders should always be zeroed after transporting the machine. Follow the process described below.

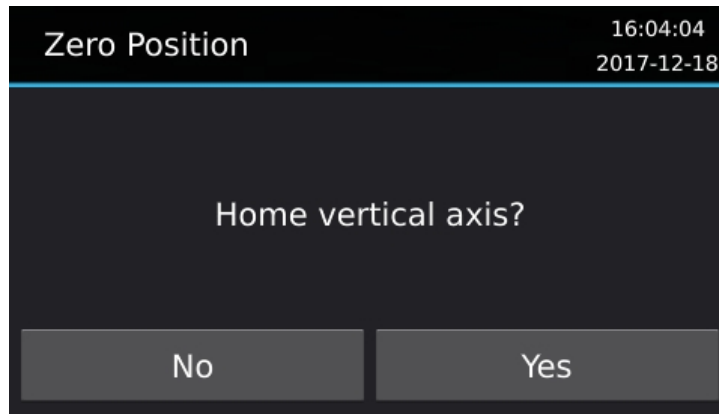

Zero Position Encoders

The PRO 4K is equipped with four position encoders built into the corners of the glass base-plate. The position encoders allow microscopic deflections in the mechanical structure to be measured during the formation of a model layer. This allows layers having precise thickness to be formed.

The position encoders should be zeroed after transporting the machine. In addition, the position encoders may drift so they should also be zeroed from time-to-time by the user. The procedure takes less than 30 seconds. The procedure for zeroing the position encoders is as follows:

1. Open the menu item Maintenance > Position Encoders.

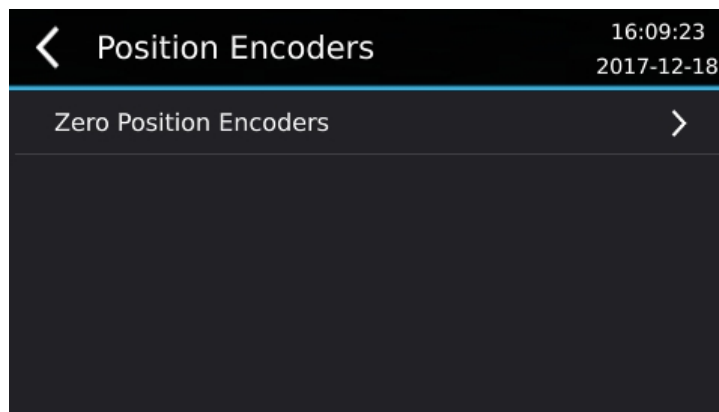

2. Press "Zero Position Encoders".

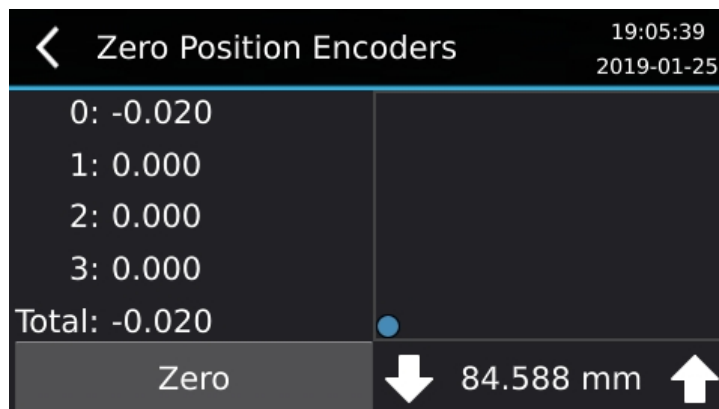

3. The empty square region shows a two-dimensional deflection map of the build envelope with a blue dot at the zero center. Pressing the up and down arrows will move the vertical axis up and down. The current height in mm above the zero position is shown between the arrows.

4. Pressing the “Zero” button will show the following prompt:

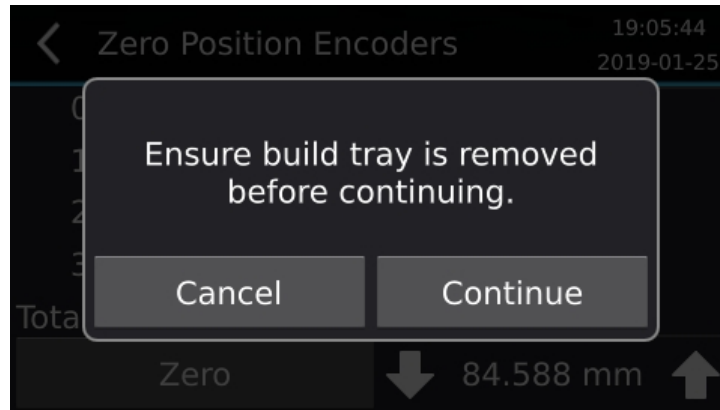

5. Remove the build tray from the machine. **There should be no objects in the build tray area or anything pressing on the machine.** The machine should be on a level surface in a low vibration area. Press “Cancel” to abort the process, otherwise, when ready, click “Continue” to record the zero position.

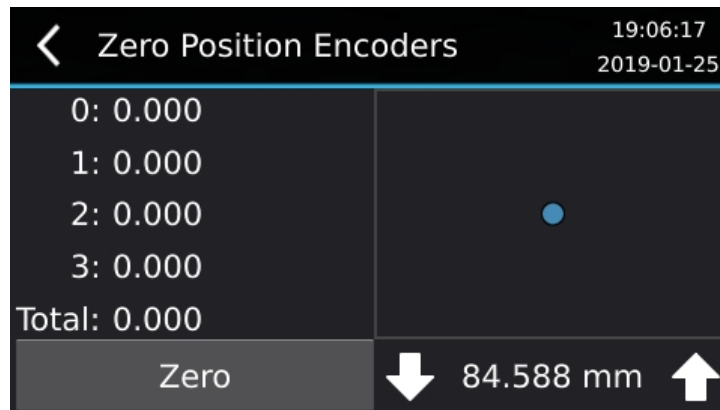

6. The process is complete. The blue dot should be in the center of the square.

Refresh Projector Motor Positions

The projector has lenses that are electronically controllable using motors. As these lenses are not locked in place, they may move during transport. To correct for this, the projector motor positions should be refreshed after transport. This sends the motors to their home positions then returns them to their calibrated positions.

To refresh the projector motor positions:

1. Go to Maintenance > Focus.
2. Press “Refresh” button and then press “Yes” to confirm.

Network Connection

Build jobs for the PRO 4K are prepared on a personal computer and sent to the PRO 4K via a network connection. The PRO 4K has two networking options:

1. Ethernet 10/100 port on the rear of the machine
2. Wireless
3. Wireless Direct

Ethernet Setup

Plug one end of the included network cable (RJ45 connector at both ends) into the Ethernet port at the rear of your PRO 4K machine. Plug the other end into a hub/switch/router on the same network as your computer. Alternatively, if there is no network, you can plug it directly into your computer.

The default network setting is Automatic Configuration, which allows your network to automatically assign an IP address to the PRO 4K machine if there is a DHCP server present. If there is no DHCP server present, the PRO 4K will fall back to Automatic Private IP Addressing to assign an unused address in range 169.254.1.0 to 169.254.254.255 with a subnet mask of 255.255.0.0.

If you wish to assign a fixed IP address to the PRO 4K machine for Ethernet:

1. Go to Settings > Wired Network
2. Toggle off Automatic Configuration
3. Select IP Address, enter the IP address and select Save
4. Select Subnet Mask, enter the subnet mask and select Save
5. Setting the Gateway, Primary DNS and Secondary DNS is optional and may be left blank

Wireless Setup

1. Go to Settings > Wireless Network
2. Select Network Name
3. Select the desired wireless network from the list. Wireless networks that require a password will have a lock icon shown.
4. If required, enter the password and select Connect. The password will be remembered so that the printer can reconnect again if the wireless connection is interrupted, the printer is restarted or the printer is turned off and on.
5. A spinning circle animation will be shown while the printer is connecting to the network. If the printer has connected successfully, a tick icon will be shown.

If your wireless network does not have a DHCP server present, you may need to assign a fixed IP address as detailed in the Ethernet Setup section.

Wireless Direct Setup

Wireless Direct allows the printer to act as a wireless access point for connecting to the printer wirelessly. This may be useful if you do not have a wireless access pointer or router that the printer can connect to. Note that enabling Wireless Direct will prevent connecting to an existing wireless network using Wireless Setup.

1. Go to Settings > Wireless Direct
2. Toggle on Enabled

By default, the printer will create a wireless network with the name set to the printer's name and the password will be randomly generated. You can select Network Name or Password to change them.

The printer will have an IP address of 172.27.10.1 with subnet mask 255.255.255.0. It will also act as a DHCP server and assign IP addresses in the range 172.27.10.2 to

172.27.10.254 to wireless devices that connect to it. The IP address and subnet mask of the printer cannot be changed when using Wireless Direct.

Install Composer Software

Build jobs for the PRO 4K are prepared on a personal computer using Asiga Composer™ software. Asiga Composer™ software is provided on the USB stick included with your PRO 4K or can be downloaded from the Asiga website. Asiga Composer™ runs on Windows, Mac and Linux.

To install Composer:

1. Insert the USB stick into a USB port of your computer.
2. Browse to the folder “Composer Software”.
 - a. For Windows click “composer-XXXX-win32.exe” or “composer-XXXX-win64.exe” depending on whether your operating system is 32-bit or 64-bit respectively.
 - b. For Mac click “composer-XXXX-x86_64.dmg”.
 - c. For Linux click “composer-XXXX-i686.tar.xz” or “composer-XXXX-x86_64.tar.xz” depending on whether your operating system is 32-bit or 64-bit respectively.

CHAPTER 3

Preparing a Build

Build jobs for the PRO 4K are prepared on a personal computer using Asiga Composer™ software. Refer to the Composer User Guide for more information.

CHAPTER 4

Starting a Build

Installing the Vat

1. Open the hood of the machine.
2. Insert the vat with the vat sensor sticker located towards the back of the machine.

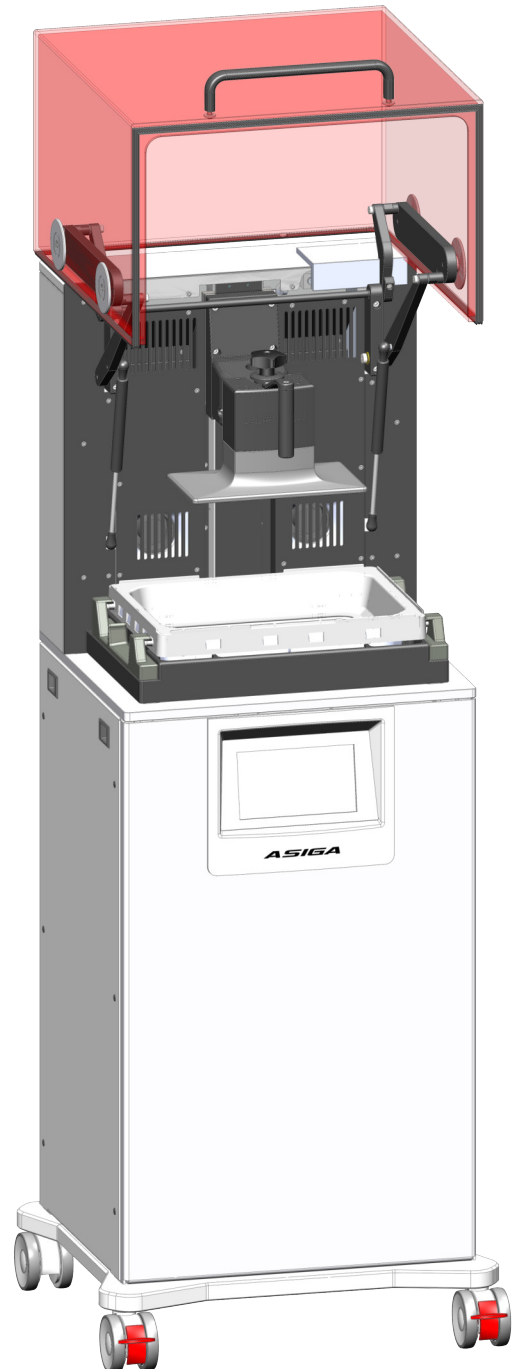
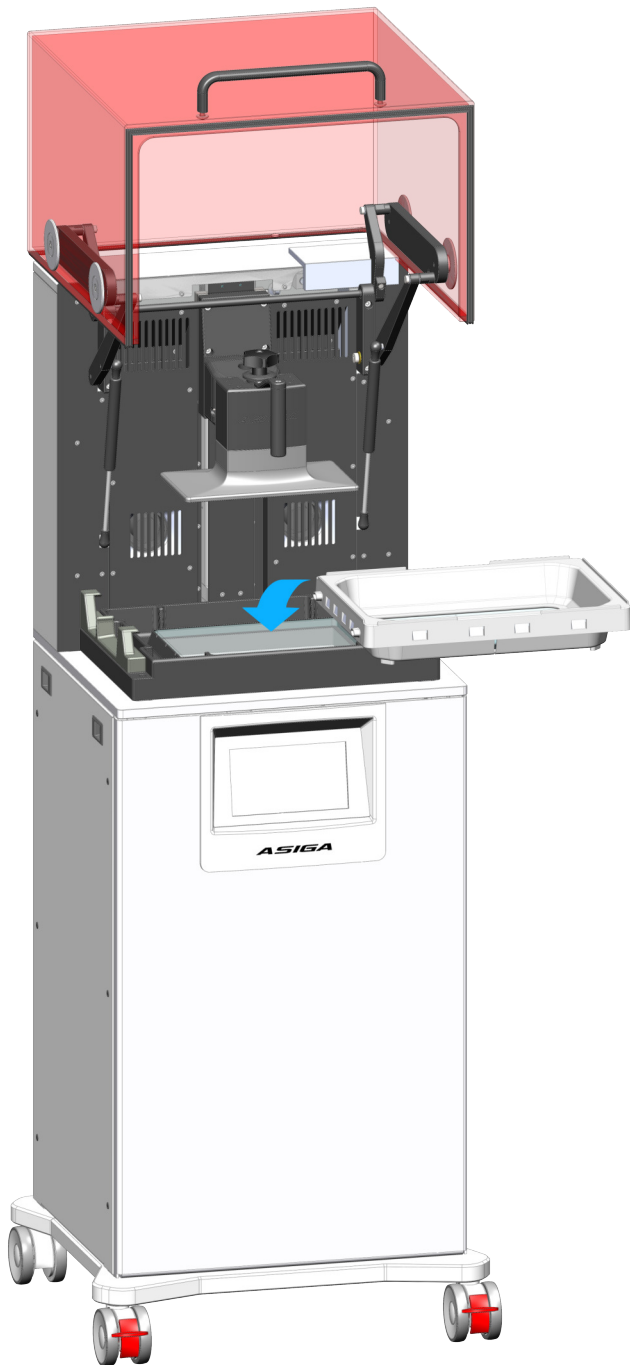

- Slide the vat latches to the front of the machine so they grip over the lugs on the sides of the vat.

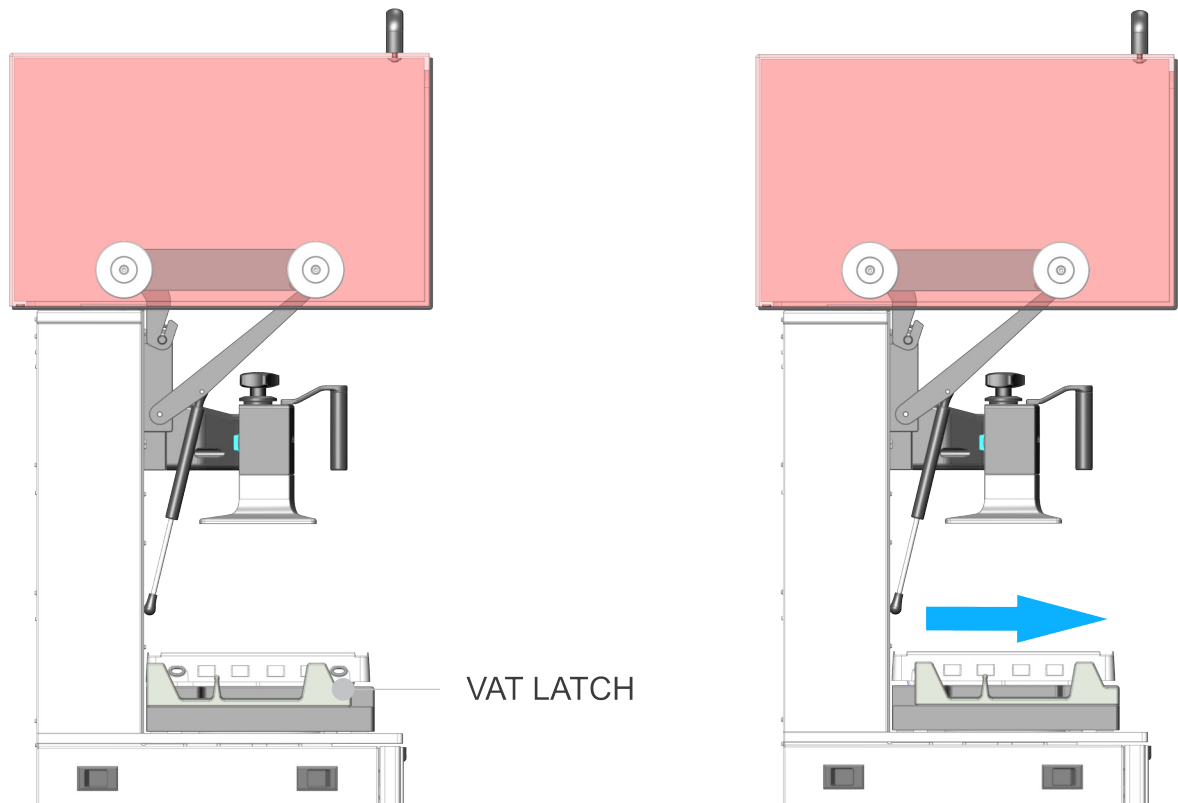

Add Resin to the Vat

The resin height in the vat should be sufficient to keep the bottom film covered with resin during the print. Approximately 10mm of resin depth is generally sufficient.

See 'MAX LEVEL' mark on vat sticker.

Clean the Vat Bottom

Note: Refer to the video on this topic included on the USB stick that shipped with your PRO 4K machine.

Commencing a build when there is solid debris in the vat can cause damage to the vat film. Debris can result whenever:

1. A part has failed to print correctly.
2. A model breaks during fabrication.
3. Resin in the vat is exposed to light.

It is prudent to check the vat bottom for any solid debris before every print. Do this by wiping resin away from the bottom of the vat with a piece of cardboard (a business card is ideal). Any cured debris can be aggregated by blanket exposing the build envelope with UV light from the projector. The following procedure should be used:

1. Go to Control > LED from the Main Menu and press the "Start" button on the LCD screen. Allow exposure for approximately 20 seconds or until a firm layer is achieved, then switch off the LED by pressing the "Stop" button on the LCD screen.

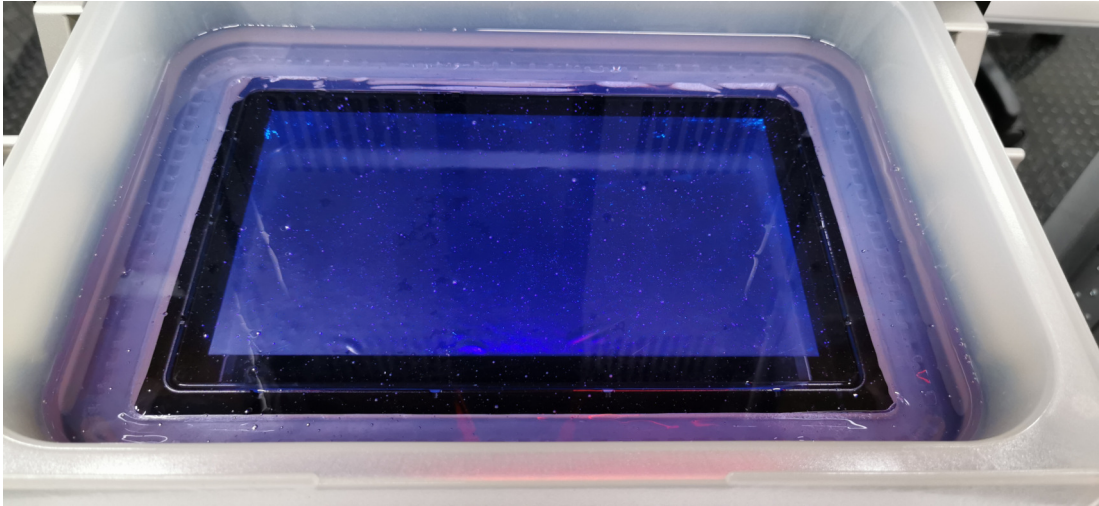

2. Remove the vat from the machine. There will be a cured rectangle of material adhered to the vat bottom.



3. Place a finger on the underside of the vat film at a corner of the cured rectangle. Your finger will provide support for the next step.
4. Use a piece of cardboard or plastic film to slide under the edge of the cured rectangle and lift it off the Teflon film.



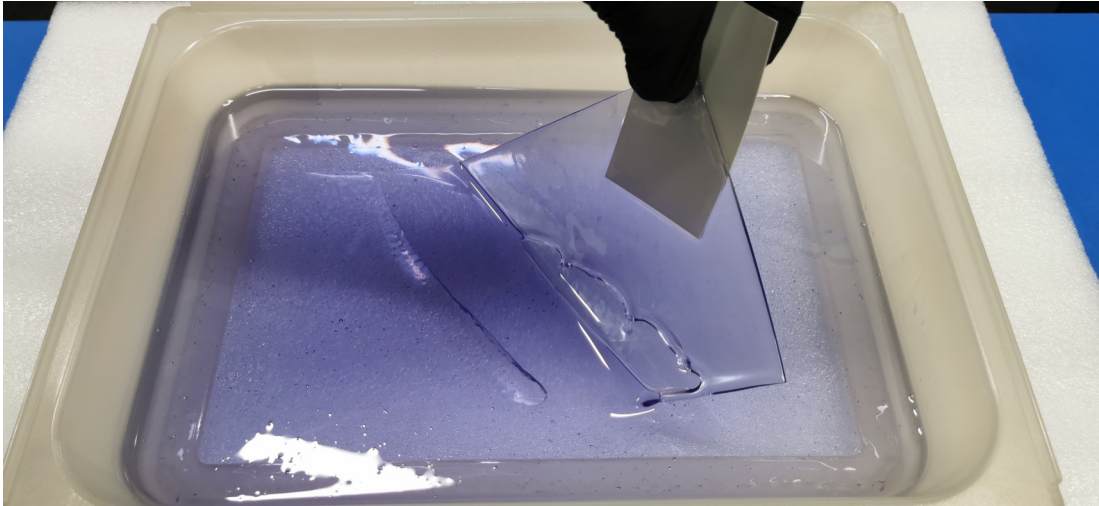

5. Remove the cured rectangle in one piece and dispose of it.

Set the Chamber Temperature

The PRO 4K is equipped with an internal temperature controller which regulates the temperature of the build chamber. Temperature control is useful when building with some materials to control their viscosity, reactivity and solidification.

The chamber temperature can be set for when:

1. The machine is idle (i.e. not building any parts)
2. The machine is building a part.

The idle chamber temperature settings are accessed via the menu **Settings > Temperature**.

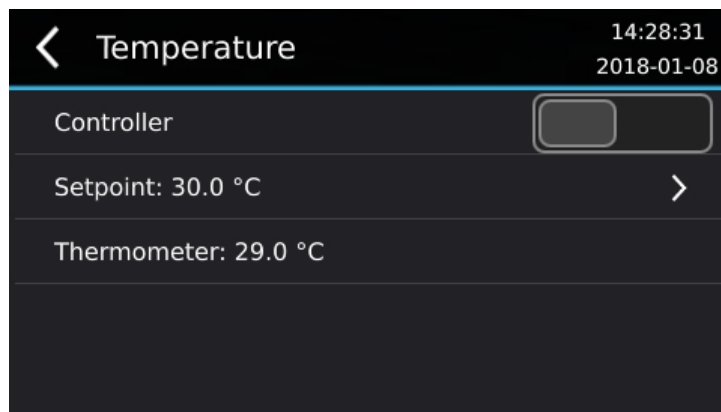

The Controller toggle allows the temperature controller to be activated or deactivated.

The Setpoint sub-menu allows the setpoint temperature to be entered.

The Thermometer field shows the current chamber temperature.

Note that the controller and setpoint settings under this menu are only employed while the machine is idle. Use this menu to control the temperature of the material while the machine is not building parts. When the machine is building a part, the build temperature setpoint set in the Asiga Composer Build Wizard is applied.

Starting the Build

Start the build on the PRO 4K's LCD screen with Print menu. There are either 3 or 4 options present:

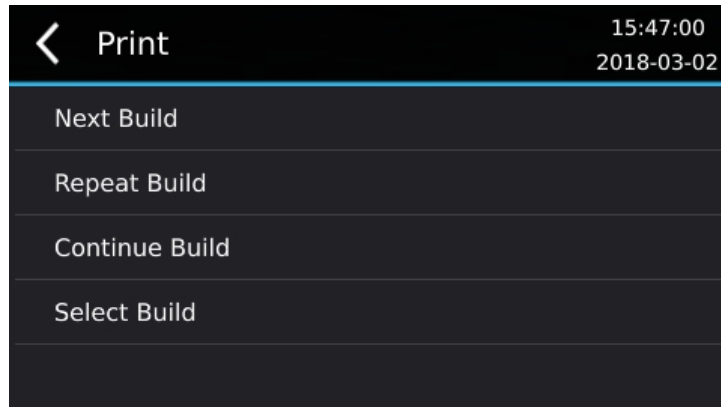

1. New Build. Starts the next build in the build queue.
2. Repeat Build. Repeats the previously started build.
3. Continue Build. Continues the current job that was either aborted by the user or halted by power failure. This option is only visible if the previous build was canceled before completion.
4. Select Build. Shows a list of jobs in the build queue and allows a build to be selected.

Stopping and Pausing the Build

A build can be paused by pressing the back arrow.

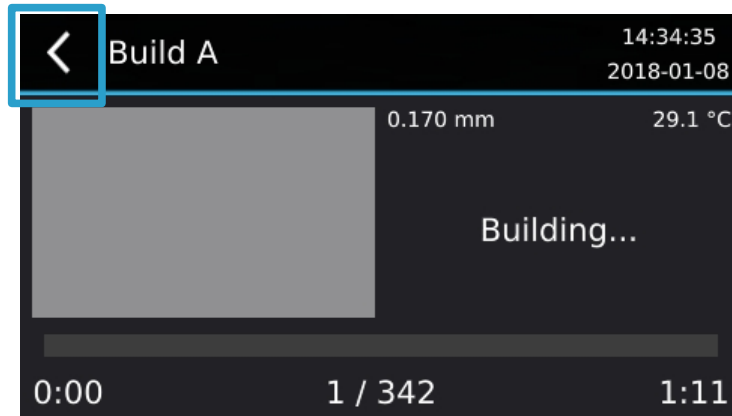

When the build is paused you can raise or lower the build using the screen buttons. You can continue the build with the Resume button or abort the build with the Cancel button.

Canceled builds can be continued with the **Print > Continue Job** menu item.

CHAPTER 5

Web Interface

The PRO 4K runs an internal web server which is visible to web browsers on the same network. This Web Interface presents important control screens for interacting with the PRO 4K.

Accessing the Web Interface

There are two ways of accessing the web interface:

1. Click on the “Web Interface” button in the Composer toolbar.

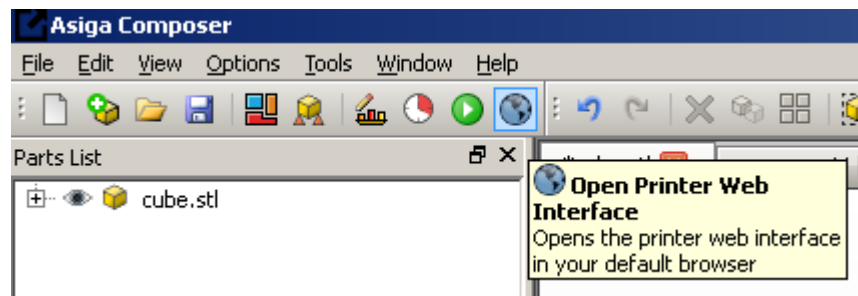

2. Open a web browser and type into the navigation bar “http://” followed by either the name of your printer or the IP address or printer, e.g.:
 - a. `http://FREEFORM-D06D10`
 - b. `http://192.168.1.53`
3. Press Enter.

There are 6 tabs in the Web Interface: Build Queue, Front Panel, Settings, System Information, Update Firmware and Support.

ASIGA Pro 4K UV385

Build Name	Build Time	Computer	Username	Added
j247	1 hr 53 mins 40 s	teststation	User	2020-04-08 12:18:30 AM

Order	Build Name	Build Time	Computer	Username	Added	Delete
▼▲	fabdent	1 hr 56 mins 38 s	teststation	User	2020-04-08 12:18:30 AM	X

Build Queue Tab

The build queue allows you to view information about the current build and queued builds.

The Current Build field shows the last build that was started. Selecting Print > Repeat Build will run this job again.

The Queued Builds list shows the list of jobs that have been submitted to the printer in order of receipt. Selecting Print > Next Build from the front panel will print the first build in the Queued Builds list. Selecting Print > Select Build from the front panel will allow you to choose any builds from the queued builds list.

Further columns indicate data about the builds:

Build Time – Estimated time for printing

Computer – Name of the computer that uploaded the build

Username – Name of the user that uploaded the build

Added – Date/time the build was uploaded

Queued builds may be reordered by clicking the up/down arrows ▼▲ next to the build name or by dragging and dropping. A build can be deleted by clicking the Delete icon ✖.

You can click the information icon ⓘ next to a build to view additional information about the build in a popup window. The following information is available:

Parts List – List of parts in the build and their dimensions

Thumbnail – A screen capture of the 3D view in Composer at the time the build wizard was started. You can click on this thumbnail image or the “Show Full-Size Image” link to show the full size image.

Download Build – Downloads a ZIP file containing the build parameters and the images displayed by the projector during exposure.

View Build Parameters – Shows the build parameters used for printing such as material name, temperature setpoint, burn-in range, separation velocity/distance, approach velocity, exposure times, etc.

Print View – Print the information shown in the window (build time, computer, username, added, parts list and thumbnail)

Front Panel Tab

The Front Panel tab allows you to see and remotely interact with the printer's touch screen from a web browser running on your computer, tablet or phone. You can interact with the front panel by pressing, releasing and dragging with a mouse on the touch screen image.

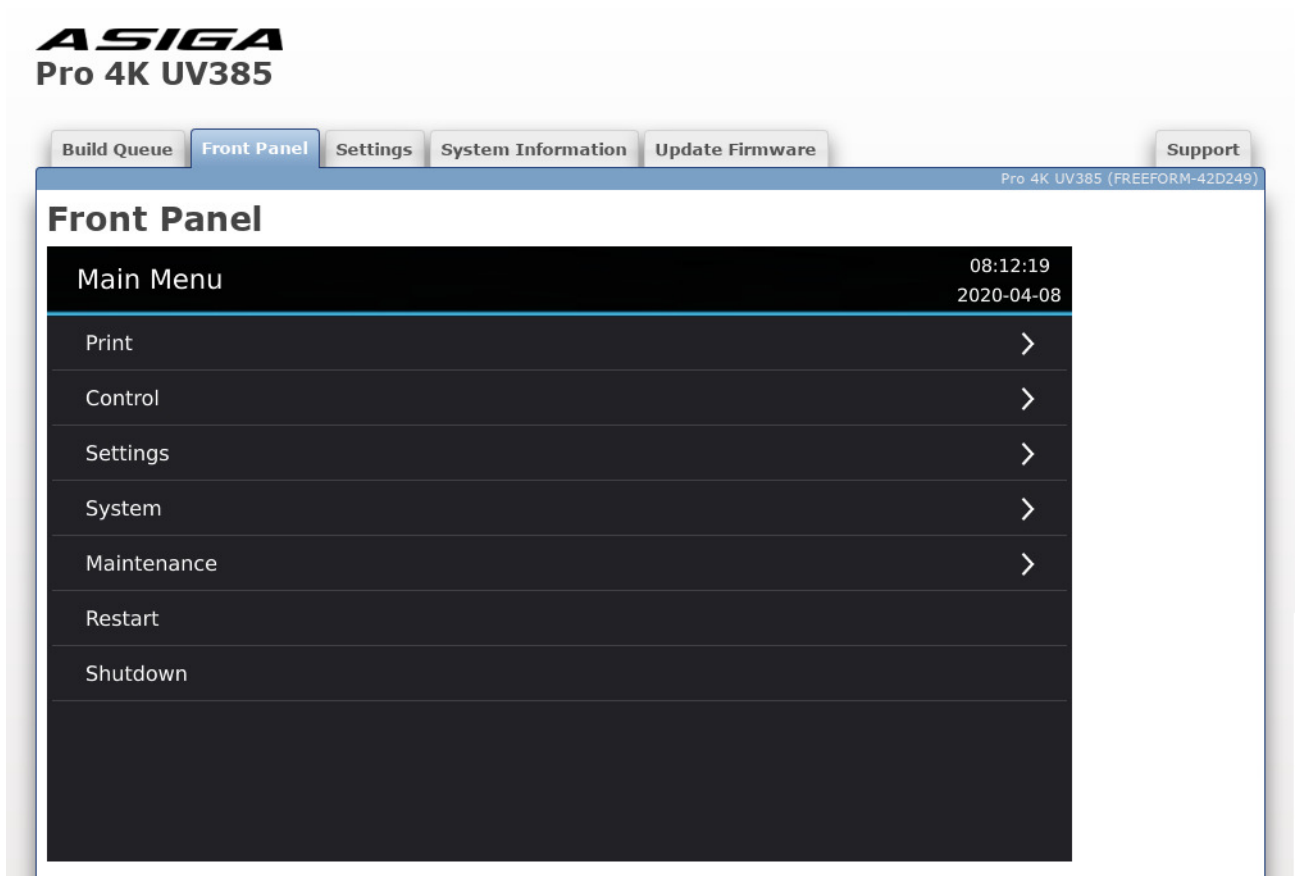

Settings Tab

The Settings tab is used to define the physical build extents and protection options of the PRO 4K machine.

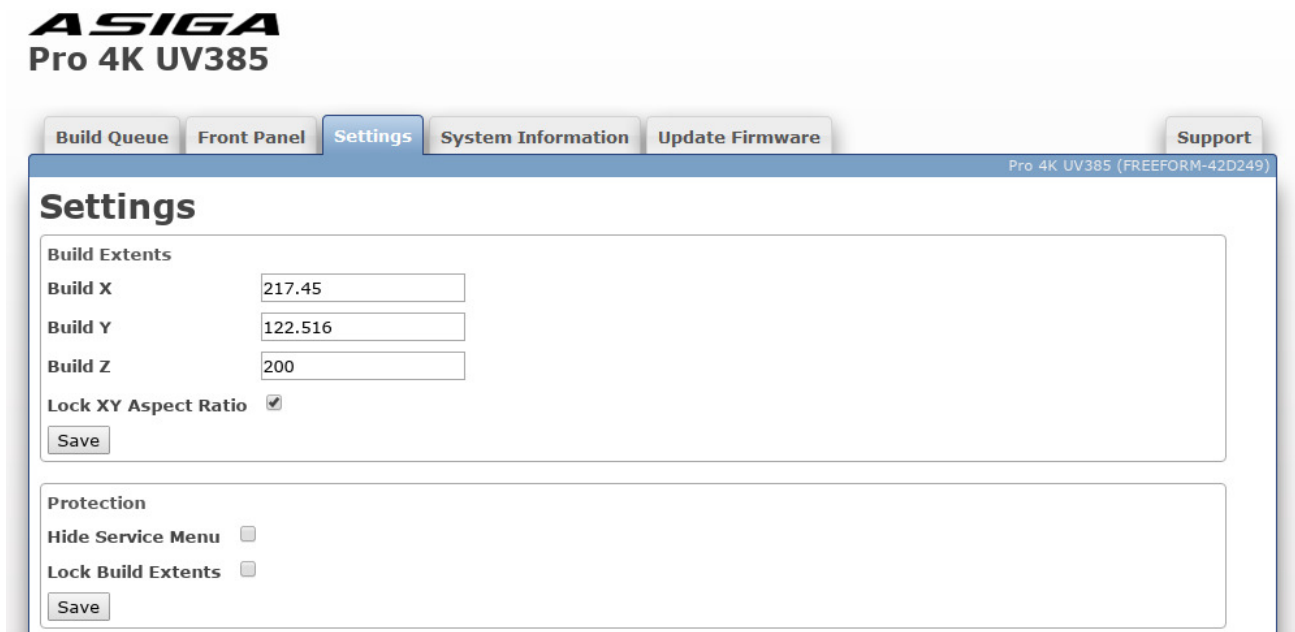

Build Extents

Build X – Width of the projected image (mm)

Build Y – Height of the projected image (mm)

Build Z – Depth of the build volume (mm)

Lock XY Aspect Ratio – Ticking this box locks the aspect ratio of the projected image to that of the imaging chip. It forces the pixels to be square.

Note: The Build Extents will be calibrated correctly when you receive your machine. Build Extents only need to be calibrated if the projector has been swapped or reinstalled. The values “Build X” and “Build Y” must be determined by experimentation. This is typically done by building an object or objects which span the build volume and measuring the actual span in the X and Y direction. A suitable build may be one which included a cube in each corner of the build volume, commonly known as a “four cubes” build. The setup in composer for such as print is as follows:

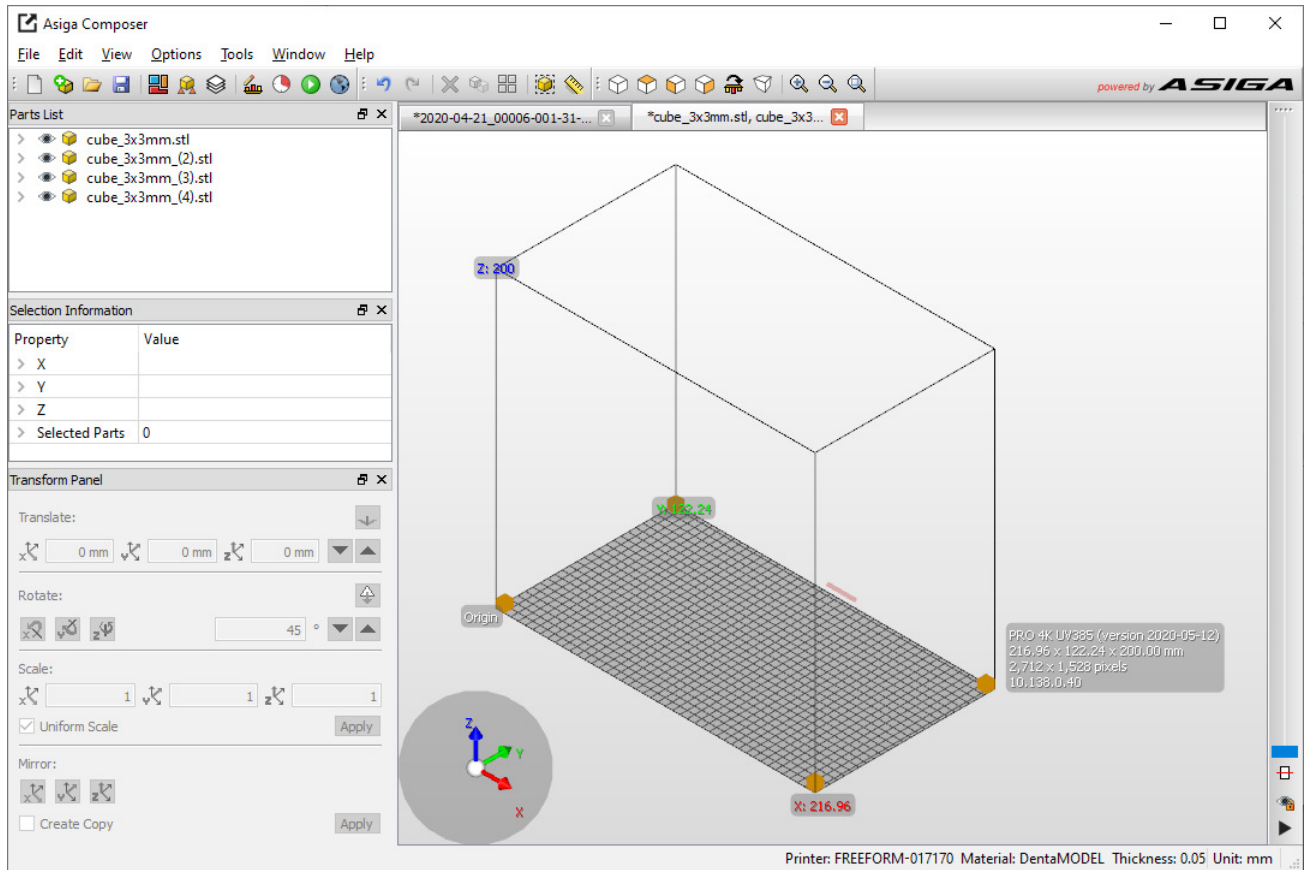

The measured X and Y span values are entered into the appropriate fields and the “Save” button is clicked to save the changes.

Note that if the “Lock XY Aspect Ratio” box is ticked the entered value for Build X will automatically update the Build Y value and vice versa. This allows the calibration technician to recheck measurements and possibly correct any keystone error in the projected image. If the “Lock XY Aspect Ratio” box is unchecked, any values can be entered for the Build X and Build Y and a square pixel is not guaranteed. Re-checking the “Lock XY Aspect Ratio” box will recalculate either Build X or Build Y to minimize the change to either value.

Note that the Build Z span is defined by the travel of the vertical axis minus the allowed separation distance.

Protection

Hide Service Menu – Ticking this box hides the Maintenance > Service menu from the Front Panel.

Lock Build Extents – Ticking this box disables the Save button for the Build Extents, preventing changes to Build X, Y and Z.

System Information Tab

The System Information tab shows useful information about the printer.

ASIGA

Pro 4K UV385

Build Queue Front Panel Settings **System Information** Update Firmware Support

Pro 4K UV385 (FREEFORM-42D249)

System Information

Model Type: PRO 4K UV385
 Serial Number: 020C0802B560
 Firmware Version: 2020-04-08

Printer Name: FREEFORM-42D249
 Local IP Address: 10.138.1.114
 Remote IP Address: 10.138.0.7
 Uptime: 1 hour 21 minutes 0 second
 CPU Usage: 0% (0%, 0%)
 Used Memory: 192 MiB
 Free Memory: 813 MiB
 Total Memory: 1006 MiB

Printer System Time: Wednesday, April 8, 2020 8:35 AM ([Update](#))

[Debug Information](#) | [Error Log](#) | [View BuildLog.ini](#) | [View printer.ini](#)

Model Type – This will be “PRO 4K” for a PRO 4K printer. If the LED output is 385nm wavelength the suffix “UV385” is added, otherwise the LED is 405nm wavelength.

Serial Number – This will be 12 hexadecimal characters (0-9, A-F). The MAC address of the wired Ethernet interface of the printer will be the same as the serial number. (e.g. a serial number of 0123456789AB corresponds to a MAC address of 01:23:45:67:89:AB).

Firmware Version – This will be the date the firmware was created (e.g. 2020-03-14) in the format YYYY-MM-DD

Printer Name – The name of the printer as visible in Composer's New Build dialog and on Windows networks. By default it is set to FREEFORM-XXXXXX where XXXXXX is the last 6 characters of the serial number.

Local IP Address – The IP address of the printer whose web interface you are accessing.

Remote IP Address – The IP address of the computer where the web browser is running.

Uptime – The amount of time the printer has been running.

CPU Usage – Estimate of the percentage of the printer's CPU utilized. A combined usage and a usage for each CPU core is shown.

Used Memory – Amount of printer's RAM currently in use.

Free Memory – Amount of printer's RAM remaining.

Total Memory – Amount of printer's RAM installed.

Printer System Time – Current date/time on the printer. The printer's clock runs in Coordinated Universal Time (UTC). For display purposes, a time zone offset can be set in Settings > Time Zone to show the clock in your desired time zone. Clicking the Update link will synchronize the printer's UTC date/time with the UTC date/time on your computer.

Debug Information – Shows a log of diagnostic messages since the printer was turned on (including error messages). The address bar of your web browser will show a URL ending in /debug. You can customize the behavior by adding some parameters to the end of the URL:

- /debug?n=100 will show only the last 100 lines
- /debug?n=20&f=1 will show only the last 20 lines and show additional lines added in realtime. Note that many web browsers will stop showing additional lines if there is no new lines after a certain amount of time. If you are using Firefox you can enter “about:config” into the address bar and change the network.http.response.timeout

preference from 300 to 0 so it doesn't stop monitoring if there are no new lines after 5 minutes (300 seconds).

Error Log – Shows a log of error messages since the printer was turned on. The address bar of your web browser will show a URL ending in /errorlog. You can customize the behavior by adding some parameters to the end of the URL:

- /errorlog?n=100 will show only the last 100 lines

View BuildLog.ini – Shows a log of builds started/canceled and information about each build

View printer.ini – Shows the printer's current configuration

Update Firmware Tab

The Update Firmware tab allows you to upload a new firmware file onto the printer.

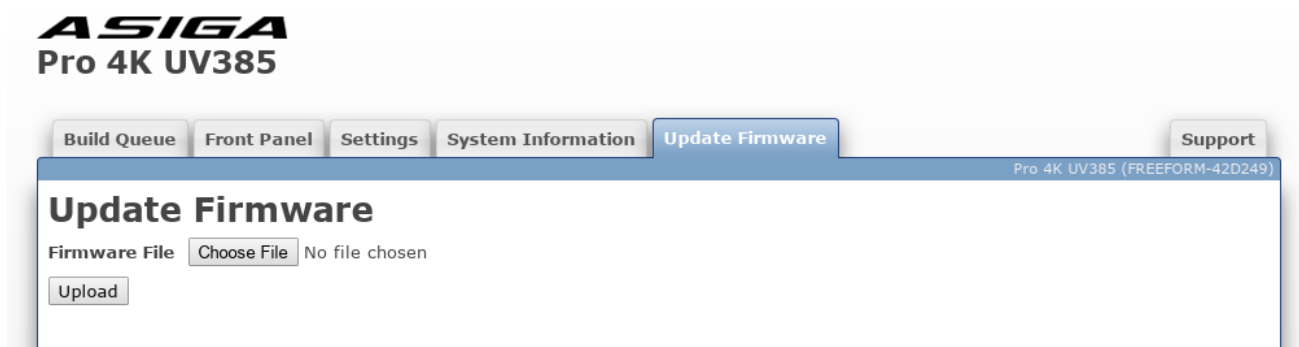

Firmware files have the file extension “.fw”. You can click Browse to select a firmware file and then click Upload to upload it. The printer will verify the firmware is valid and if it is, it will be added to the list of firmware in the System > Firmware Version menu on the front panel. You can then select the desired firmware from the Firmware Version menu to update to the selected version. The printer will keep the 5 most recently uploaded firmware files.

Support Tab

The Support tab provides contact details for obtaining support from Asiga for the printer and also provides an option to change the language of the web interface.

ASIGA

Pro 4K UV385

Build Queue Front Panel Settings System Information Update Firmware Support

Pro 4K UV385 (FREEFORM-42D249)

Support

Mailing Address
Unit 2 / 19-21 Bourke Road
Alexandria
NSW 2015
Australia

Telephone
AU: +61 2 8417 2050
US TOLL FREE: +1 877-689 99 98

Email
General Enquiries: info@asiga.com
Technical Support: support@asiga.com

Website
<http://www.asiga.com/>

Language

- Czech - cs
- English - en
- Deutsch - de
- Français - fr
- Indonesia - id
- Polski - pl
- Português - pt
- Русский - ru
- Svenska - sv

Restricted Mode
[Enable](#)

The selected language is stored in a cookie in the web browser. If no language has been selected or the web browser cookie is not present, the web browser's default language will be used if available.

The support tab also allows you to enable or disable Restricted Mode.

Restricted Mode

Restricted Mode allows you to set a password to make the Front Panel tab read-only, hide the Settings tab and disable updating the Printer system Time. This may be useful to lock down the printer to prevent users from modifying critical settings.

Restricted Mode

[Enable](#)

Clicking the Enable link will pop-up a dialog prompting you to set a password by typing it twice and clicking OK. If the passwords don't match, the OK button will not be disabled and you will not be able to continue.



A dialog box titled "Set Password" with a close button (X) in the top right corner. It contains two input fields: "New Password" and "Confirm Password". Below the input fields are two buttons: "OK" and "Cancel".

After clicking OK, the Enable link changes to Disable.

Restricted Mode
[Disable](#)

Clicking on the Disable link will prompt for the password. You can proceed with disabling Restricted Mode by either entering the password you set to enable Restricted Mode or entering the activation code from www.asiga.com/register that was used to register the printer (in case the password was forgotten).

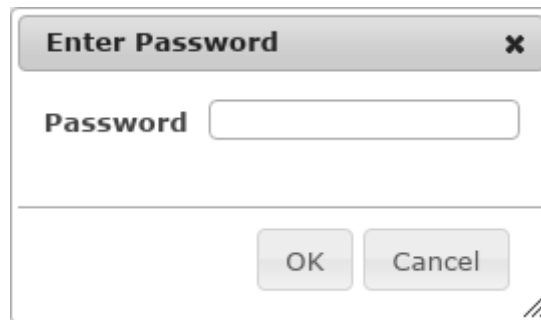

A dialog box titled "Enter Password" with a close button (X) in the top right corner. It contains one input field labeled "Password". Below the input field are two buttons: "OK" and "Cancel".

Policy Editor

The Front Panel of the printer can be customised using the policy editor. For example, menu options can be disabled or hidden in order to prevent settings changes by operators in a production environment. By default, no policy is configured, so all menu items are accessible as normal. The policy editor can be accessed by clicking on the Build Queue tab of the web interface and then replacing /queue in the web address with /policy.



The policy can be typed into the text box and applied by clicking Save. It will be applied immediately. If a text box and Save button is not shown, you need to disable Restricted Mode.

Here is an example policy that can be copied and pasted into the text box:

```
; Policy for Front Panel

;[Policy]
; This setting can be set to FALSE to disable the entire policy instead of
clearing the policy
Enabled="TRUE"

[Front Panel]
; Hide the Restart menu item
Restart/Visible="FALSE"
; Disable toggling the Hood sensor
Maintenance/Sensors/Hood/Enabled="FALSE"
; Disable changing the printer name and time zone
Settings/Printer Name/Enabled="FALSE"
Settings/Time Zone/Enabled="FALSE"
; Hide the language
Settings/Language/Visible="FALSE"

; Comment lines start with a semi-colon and can contain any text
; Additional comments
; More comments
```

Lines starting with a semi-colon are comments that are ignored and can be located anywhere in the policy. You can add/remove them as desired.

You can add/remove lines from the [Front Panel] section of the example policy to do further customization.

Lines are of the format Path/Option=Value.

- Path – the path to menu item. This can be found by setting the language to “American English” and then noting down the names of the menu items you need to press to get to the item. For example to get to Time Zone you need to press “Settings”, followed by “Time Zone”. You join them together with the “/” character to get “Settings/Time Zone” which is the path. If the menu item has a colon, everything from the colon onward is excluded when forming the path (e.g. the path for “Settings/Language: American English” is “Settings/Language”).
- Option – this can be either “Enabled” or “Visible”
 - Enabled – controls whether the menu item can be pressed or modified
 - Visible – controls whether the menu item is visible
- Value – this can be either “TRUE” or “FALSE” (be double to include the double quotes when entering it into the policy)

CHAPTER 6

Post-processing Parts

Parts build on the PRO 4K need to be removed from the build platform, washed and post-cured.

Removing Parts from the Build Platform

Use a metal scraper or razor blade to remove parts from the build platform. Wash the parts in the dirty bath. This removes the majority of the resin residue.



Then move the parts to th

Washing Parts

Resin residue remaining on printed parts can be removed by washing in isopropanol. Best practice for efficient use of isopropanol is to maintain two baths: a “dirty bath” and a “clean bath”.

First wash the parts in the dirty bath. This removes the majority of the resin residue.



Then move the parts to the clean bath. This removes the residual resin.



Parts may then be given a final rinse under water.



Compressed air may be used to dry the part.



Post-Curing Parts

Parts printed on the PRO 4K will not be fully cured initially and will consequently lack their full strength. Full strength is attained when the parts are fully cured. This can be achieved by exposing the parts to ultraviolet light.



An ultraviolet Flash unit is included with your PRO 4K. The Flash unit will be either 110V AC or 220V AC depending on your region. CHECK THE VOLTAGE REQUIREMENTS OF YOUR FLASH UNIT BEFORE USE AND VERIFY YOU ARE CONNECTING THE CORRECT VOLTAGE.

Turn on the UV unit and place the parts inside the chamber. Full strength is usually obtained in between 5 and 30 minutes.

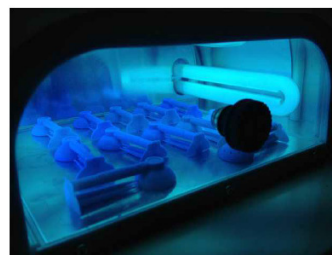

The parts may still be tacky on the surface due to atmospheric oxygen inhibiting the photo-curing reaction. Full surface cure can be obtained by immersing the parts in a liquid to

displace the oxygen and irradiating the immersed parts. Suitable liquids include oil, water and glycerol.

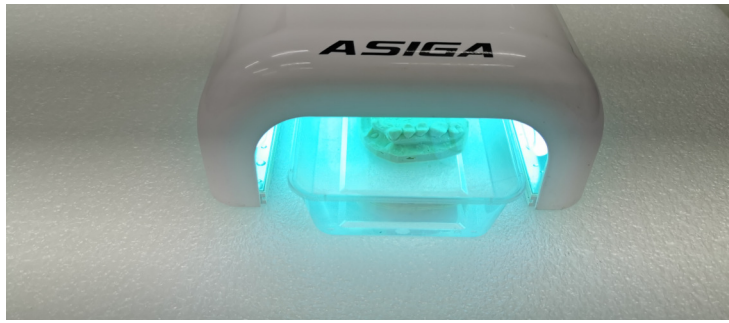

CHAPTER 7

Maintenance and Calibration

The Maintenance screen provides options for performing calibration and maintenance of your PRO 4K system.

Zero Position

Please refer to the section on Zero Position Calibration in CHAPTER 2.

Focus

To focus the PRO 4K projection system:

1. Wear UV blocking safety goggles during this procedure.
2. Remove the vat from the machine.
3. Place the Focus Plate onto the window glass with the film facing downwards.
4. Select from the main menu Maintenance > Service > Focus.

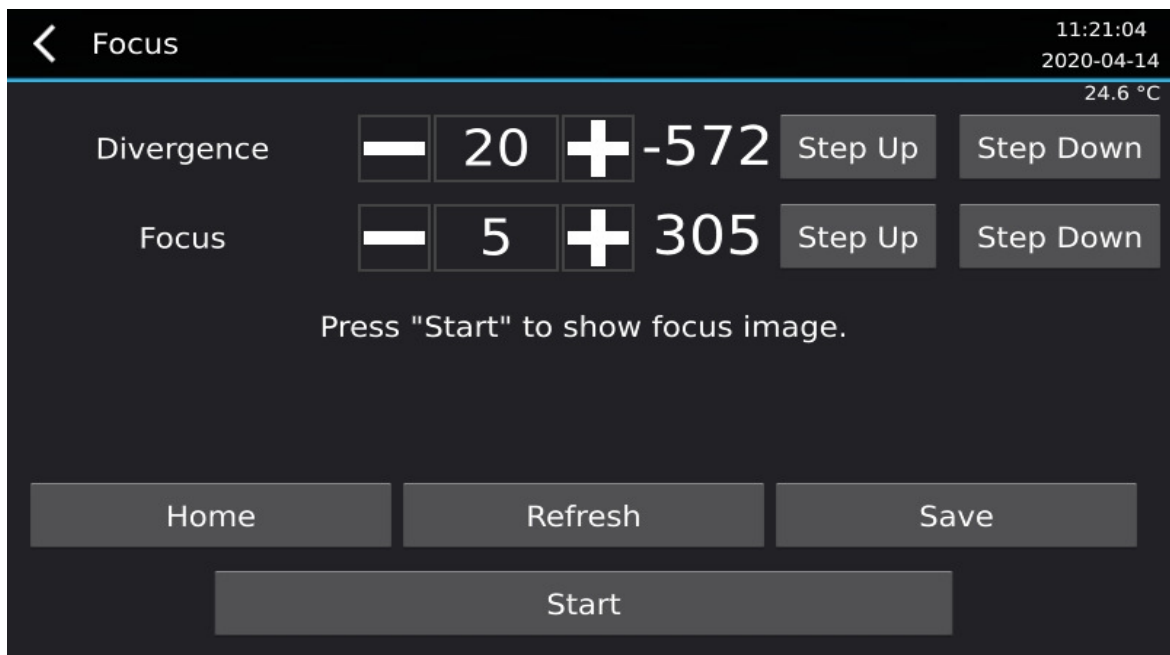

5. Press the "Start" button to show the focus grid.



6. Press the “Refresh” button. This will home the motors for the divergence and focus lens groups and then move lens back to their last saved position. This removes any positional changes resulting from transporting the printer.
7. Press the “Step Up” and “Step Down” buttons for “Focus” to adjust until best focus is achieved. The – and + buttons can be used to change the number of steps the motor will move for each button press. The minimum number of steps for the Divergence motor is 1 step. The minimum number of steps for the Focus motor is 5 steps.
8. Press the “Save” button to save the new motor positions for the divergence and focus lens groups.
9. Press the “Refresh” button. This is to verify the saved positions are correct. Confirm the focus is the same.

LED

The menu item Maintenance > LED contains options for:

1. **Radiometer:** Reading the internal radiometer value for the LED power.
2. **Power Level:** Sets the Power Level of the LED.

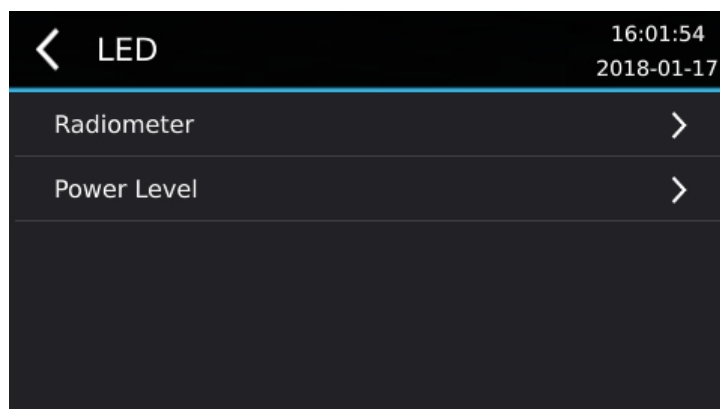

Sensors

The PRO 4K Sensors screen is reached in the menu Maintenance > Sensors. The Sensors screen shows toggles for the Hood, LED and Material Level sensors.

When the hood sensor is activated, jobs will not build if the hood is open. This can be disabled by deactivating the hood sensor.

LED intensity is checked every build layer. The build will halt if the LED intensity drops more than 50% below the starting intensity. This feature can be disabled by disabling the LED sensor.

The material level is checked every build layer. The material weight is calculated by subtracting the tray weight from the total weight and then checked against a minimum weight. If the material weight is less than the minimum weight, the build will be paused and the message “Material level is too low” will be displayed. This gives the user the chance to add more build material or cancel the build. This feature can be disabled by deactivating the Material Level sensor.

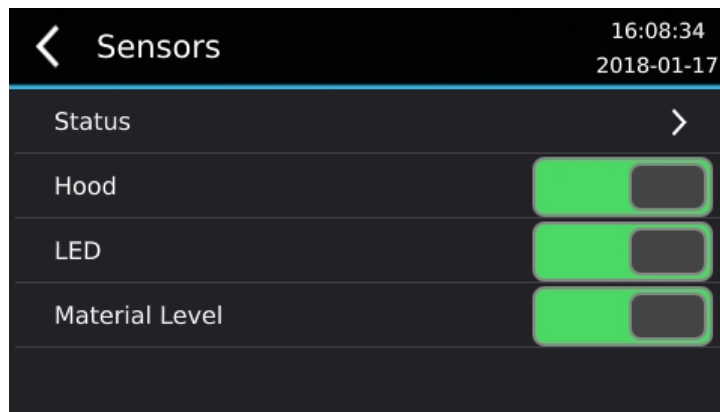

The sensor Status screen is accessed via Maintenance > Sensors > Status. This screen shows a status block for every optical sensor in the PRO 4K machine. When the sensor is activated the block is drawn in blue. When the sensor is not active the block is drawn in black.

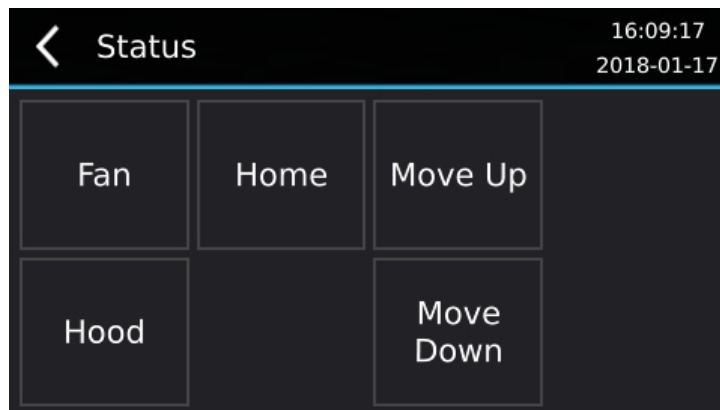

Spot Timer

The Spot Timer menu item is accessed via Maintenance > Material Test > Spot Timer. The Spot Timer is used to display a spot image for a controlled time. The Spot Timer can be used for material exposure testing.

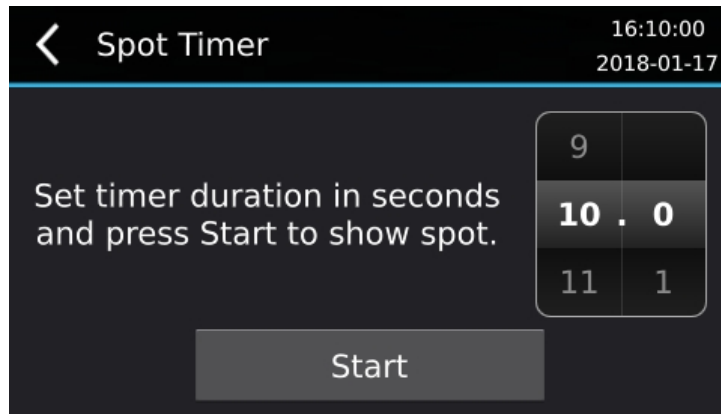

If additional control is needed over the spot image, the Material Test menu also has an option to control the spot radius and, if needed, the hole radius which allows changing the spot into an annulus.

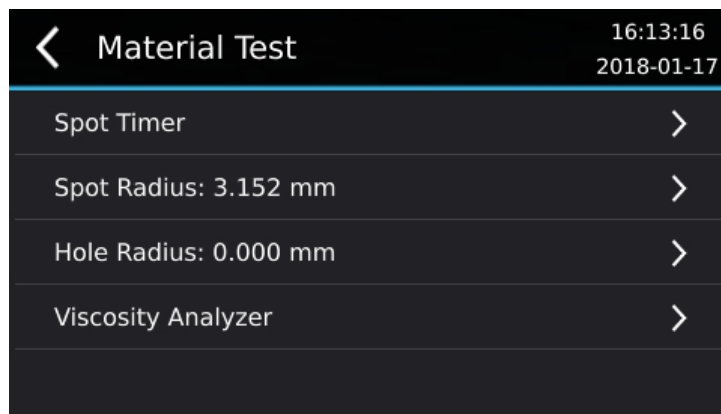

Viscosity Analyzer

The Viscosity Analyzer menu item may be used to determine the Viscosity Range of a material. The Viscosity Range parameter quantifies how viscous a material is. Its units are in millimeters. In practical terms, it measures the distance at which a surface exerts pressure against a target plate when moved towards it.

1. Go to Maintenance > Material Test > Viscosity Analyzer.

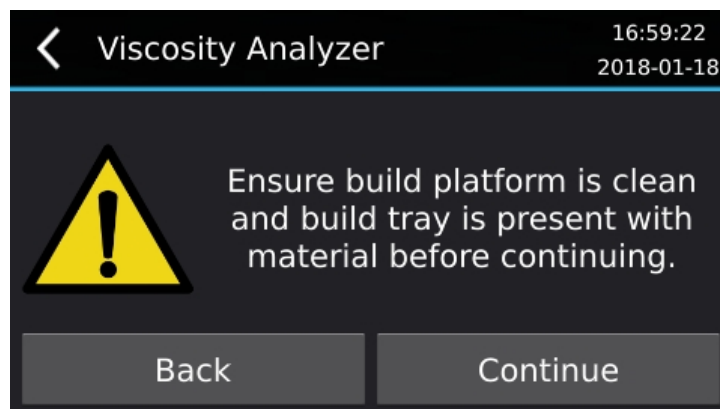

2. Install a clean build platform into the machine.
3. Install the resin vat into the machine with the desired material.
4. Define the settling time threshold. This can usually be left at the default value of 3 seconds.

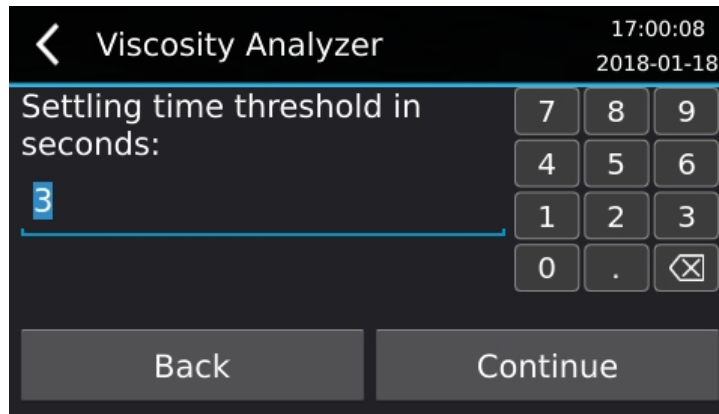

5. Press "Continue".

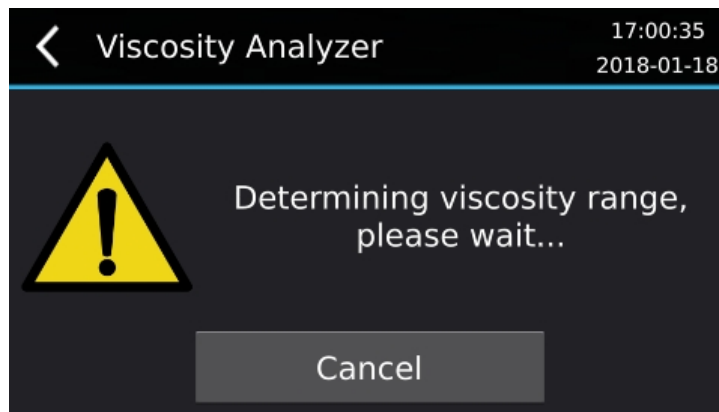

6. The platform will move down to a starting position 2 mm above the vat film in the material. It will then move down 0.1 mm and wait until the material settles (i.e. when there is no force exerted on the vat), recording the distance above the vat film and the time it takes to settle. It will repeat this until the settle time is above the settling time threshold and then interpolate the distance above the vat film which corresponds to the settling time threshold. The distance is then displayed as the viscosity range.

Materials with higher viscosity will have a higher viscosity range. The determined viscosity range gives an approximation of the ideal value for the Viscosity Range parameter included in the Advanced Parameters section of the Build Wizard in Asiga Composer.

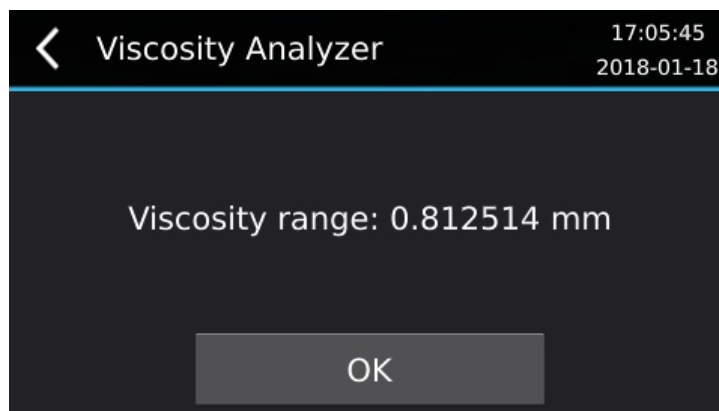

The data recorded that is used to determine the viscosity range is logged to "Debug Information" which may be accessed through the "System Information" tab of the web interface.

Clear User Data

The Clear User Data menu item deletes all pending jobs in the build queue and the current build. It also clears the BuildLog.ini file which records the attributes of recent jobs built on the machine.

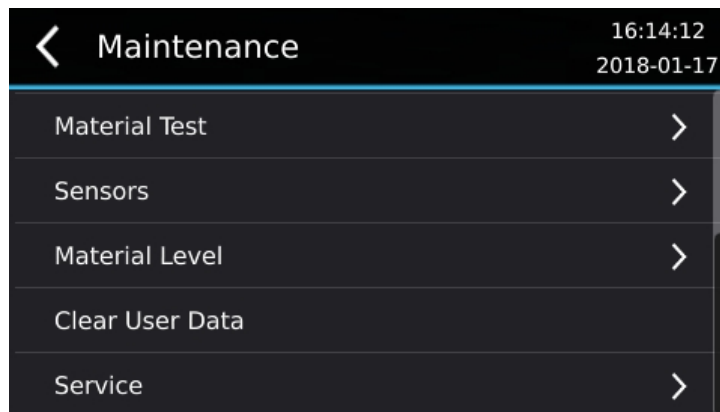

This function may be used when the machine is sold or confidential build jobs are on the machine.

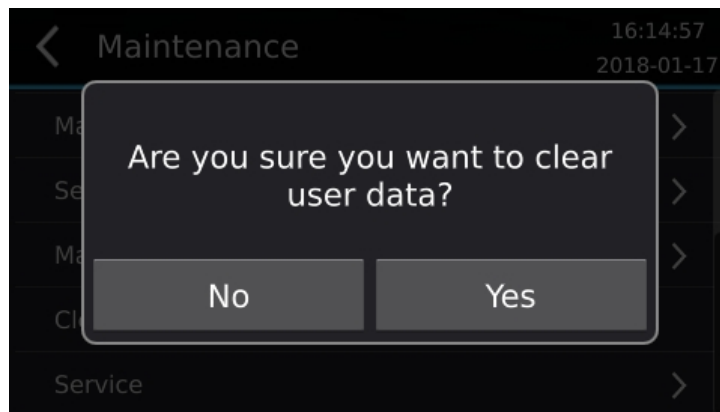

Test Parallelism

A dome nut may be used to test how parallel the platform is to the glass. This is done by placing the dome nut within each corner under the platform and having the machine move down to measure the point of contact of each corner. The difference in contact heights can be used to determine the degree of parallelism.

1. Go to menu item Maintenance > Position Encoders > Test Parallelism

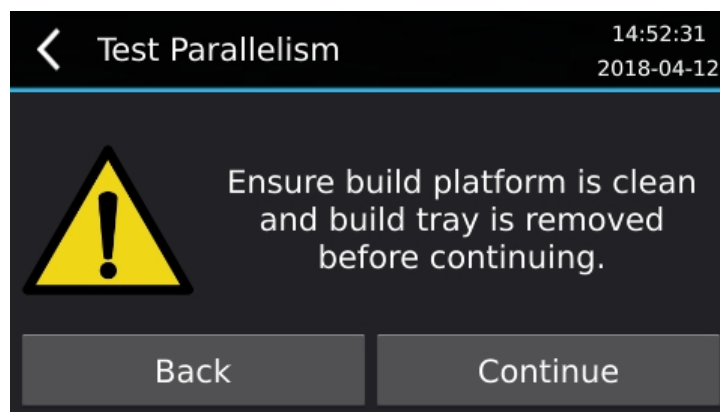

2. Install a clean build platform into the machine.
3. Remove the resin vat from the machine.

- Place a dome nut flat underneath the platform and press “Continue”.
- Use the “Move Up” and “Move Down” buttons to jog the platform close to the dome nut. Be sure only to move close to the object and not collide with it. If you do collide with object, the vertical axis will need be homed again by returning to the main menu and selecting Control > Vertical Axis > Home before trying again. Press “Next” when the platform is close to the dome nut.

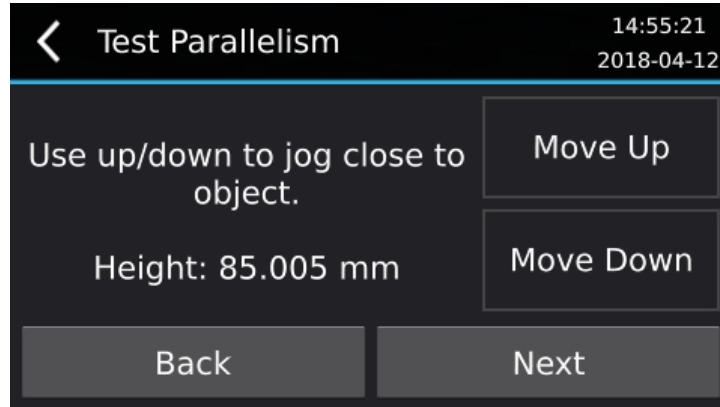

Use the hex tool from the MAX Calibration Tool Kit to move the nut around underneath the platform in subsequent steps. Avoid touching the platform and glass with your hands or the hex tool.

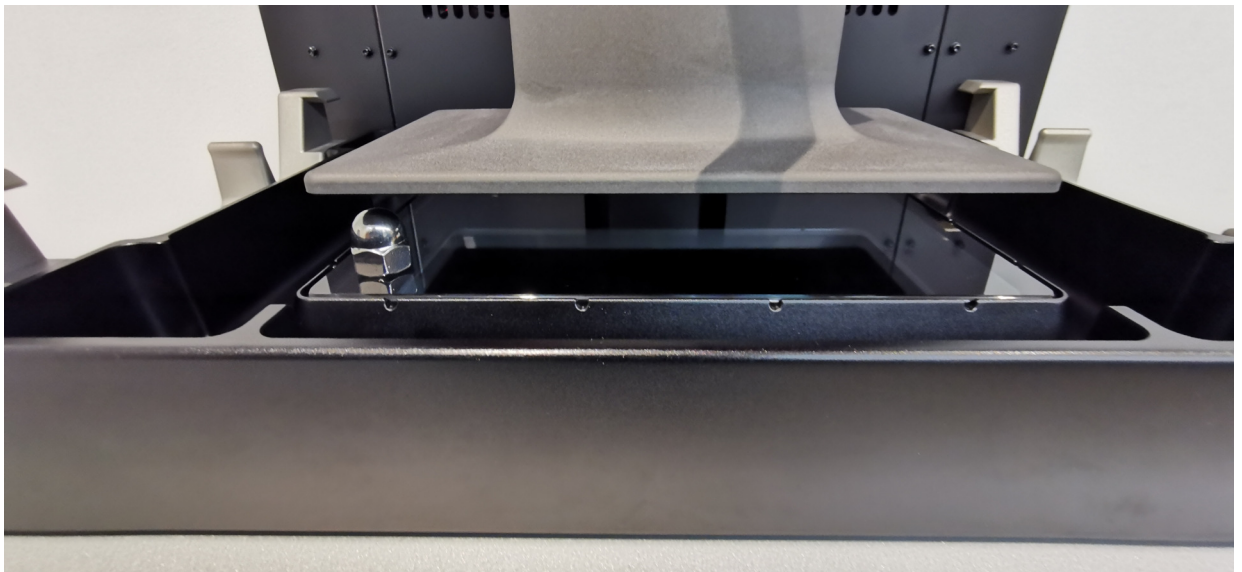

- Move the dome nut to the front left corner. The dome nut should be resting within the glass and completely underneath the platform.

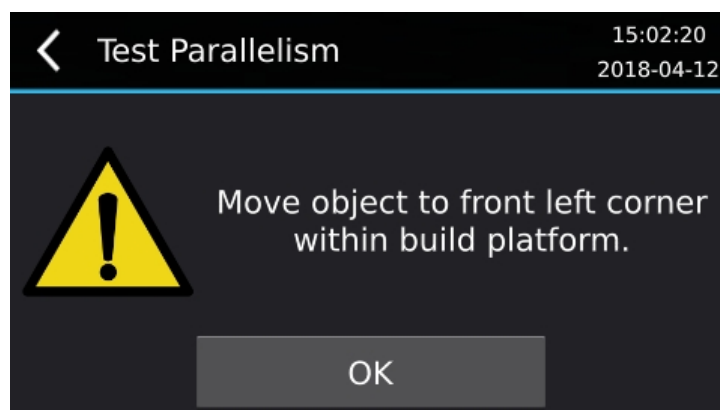

Press “OK”.

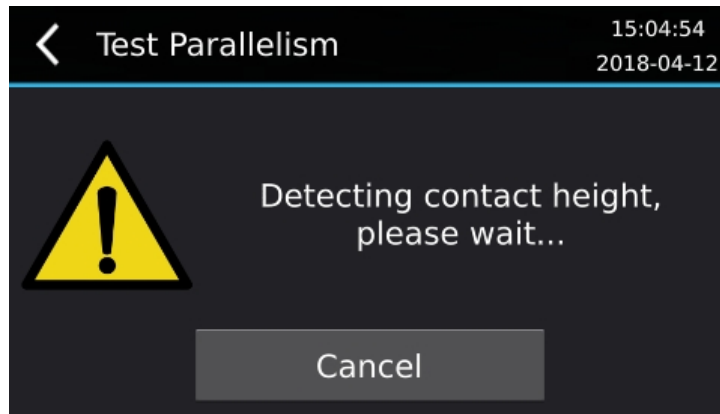

The platform will move down and the contact height will be detected when it comes into contact with the dome nut.

7. Move the dome nut to the front right corner. The dome nut should be resting within the glass and completely underneath the platform.

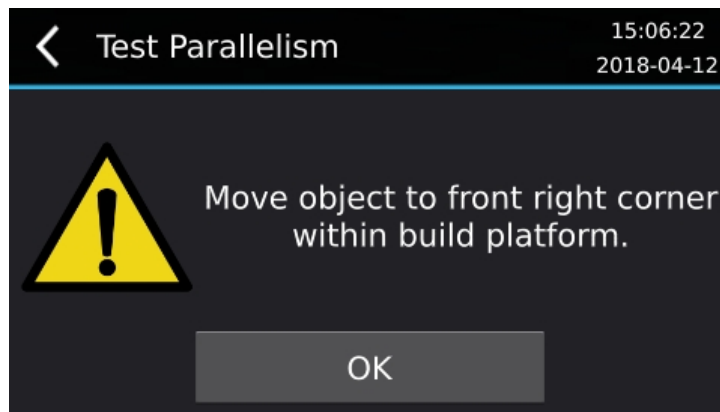

Press "OK".

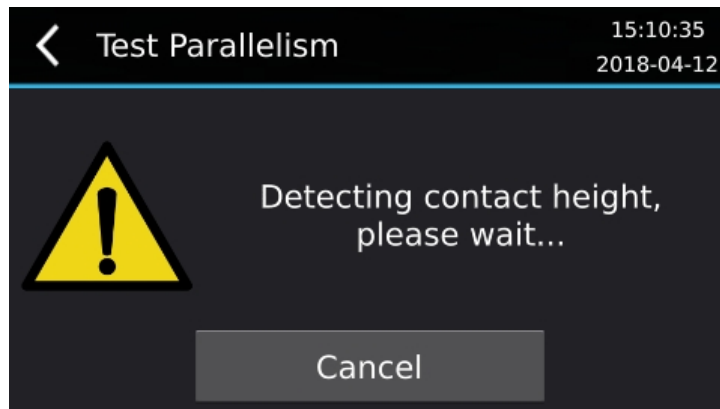

The platform will move down and the contact height will be detected when it comes into contact with the dome nut.

8. Move the dome nut to the back right corner. The dome nut should be resting within the glass and completely underneath the platform.

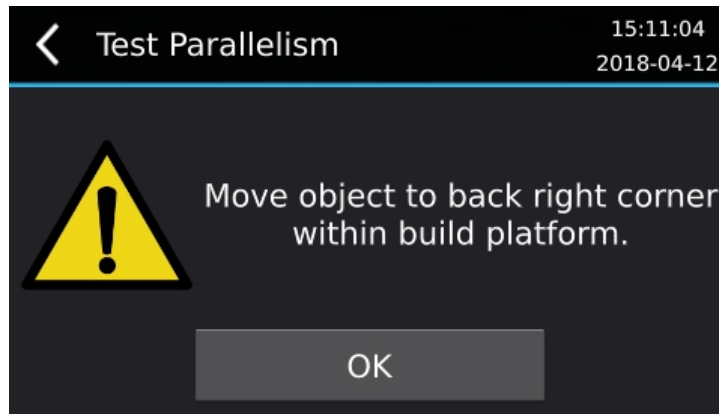

Press "OK".

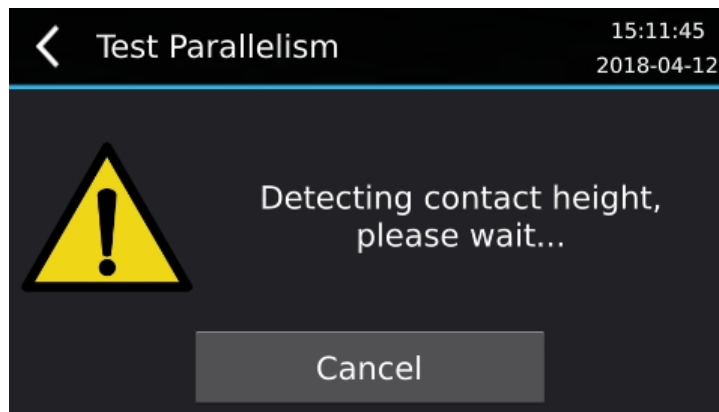

The platform will move down and the contact height will be detected when it comes into contact with the dome nut.

9. Move the dome nut to the back left corner. The dome nut should be resting within the glass and completely underneath the platform.

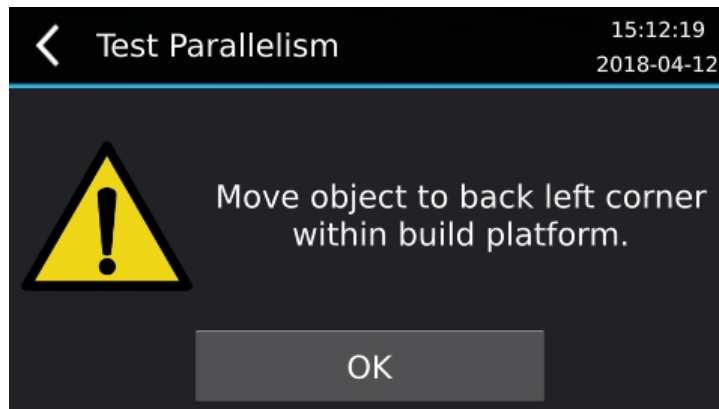

Press "OK".

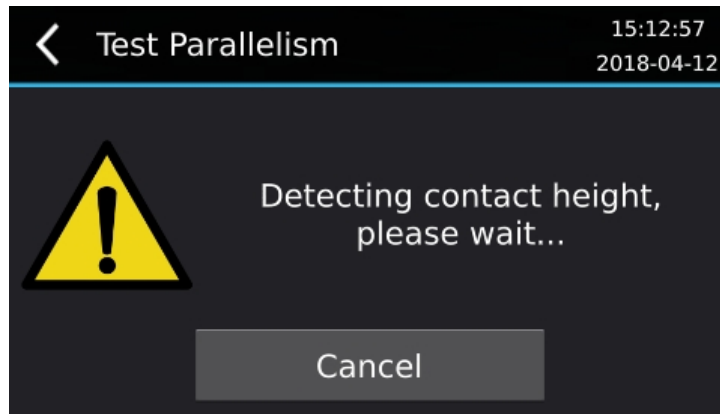

The platform will move down and the contact height will be detected when it comes into contact with the dome nut.

10. Remove the dome nut from the machine.

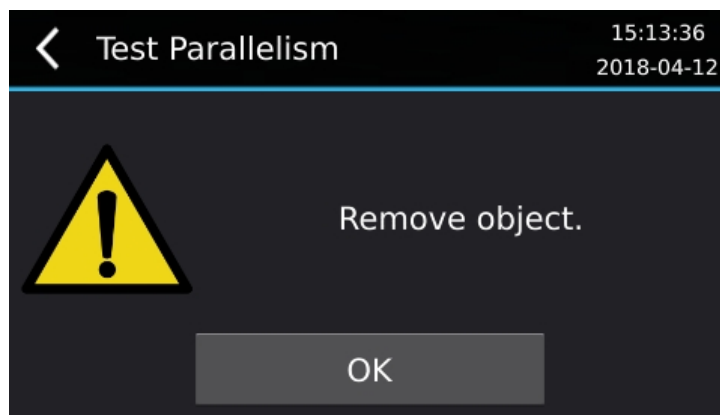

Press "OK".

11. The minimum contact height is determined and then the contact height of each corner relative to the minimum corner is shown. The center of the screen shows the maximum contact height. Higher values indicate a larger distance between the glass and the corner. The lowest contact point is shown as 0.000 mm.

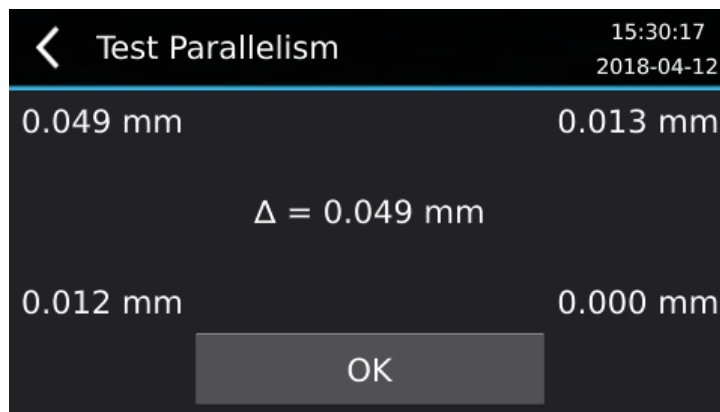

Show During Build

The position encoders can be shown during build instead of the "Building..." message.

1. Go to menu item Maintenance > Position Encoders

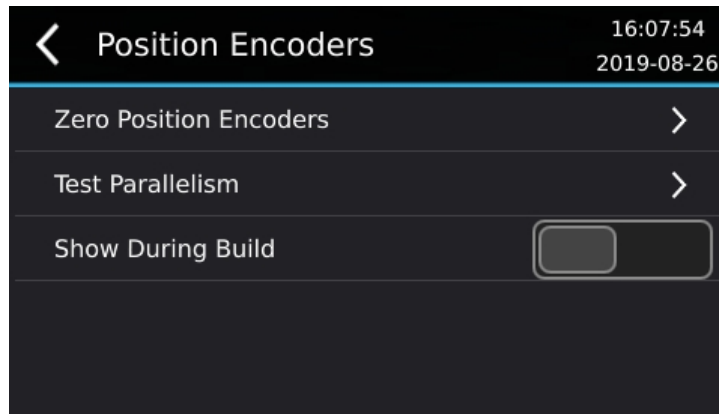

2. Activating the option “Show During Build” will show the position encoders values and blue dot while building similar to the Zero Position Encoders screen.

The values for the individual encoders are displayed in counter-clockwise order starting from the bottom-left of the right half of the screen:

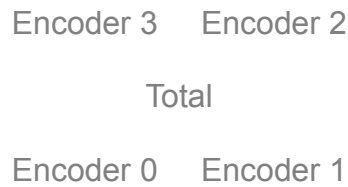

The total shown in the middle is the sum of the individual encoder values.

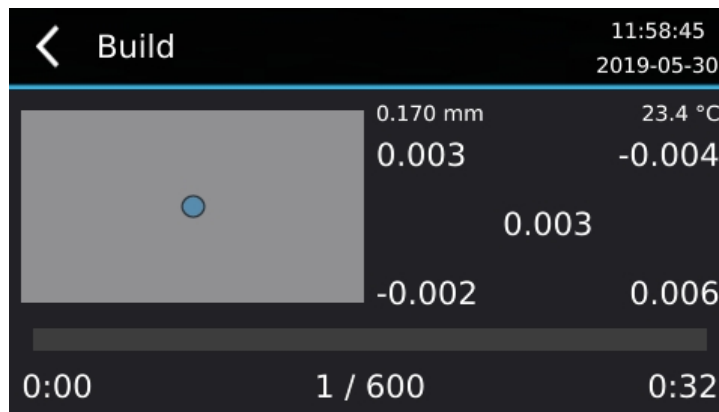

Deactivating the option “Show During Build” will show the text “Building...” while building instead of the position encoder values and blue dot.

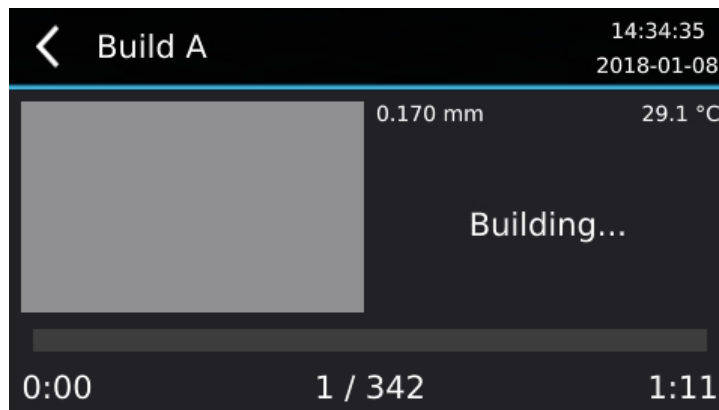

CHAPTER 8

Service

The Service menu is accessed by going to Maintenance > Service.

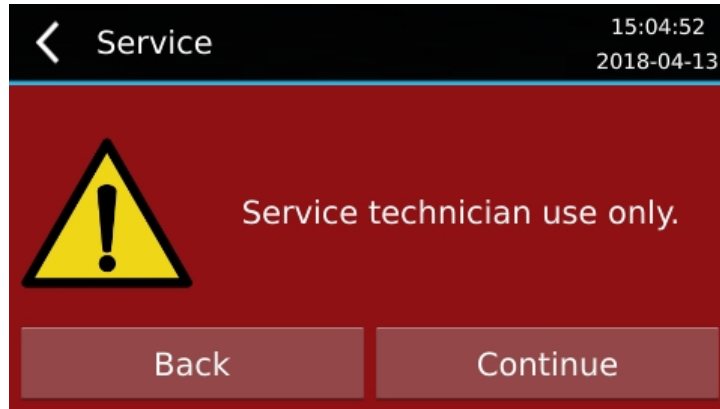

This menu is for service technician use only and there is no need for users to access this menu. Some menu items from the Maintenance menu are duplicated into the Service menu for convenience.

Bottom Limit

The menu item Maintenance > Service > Bottom Limit sets the lowest position of the vertical axis. This is set at the factory. There is no need for users to set the bottom limit unless the memory card of your PRO 4K has been replaced. **NOTE THAT INCORRECT SETTING OF THE BOTTOM LIMIT CAN RESULT IN DAMAGE TO YOUR MACHINE.** If you are required to set the bottom limit, do not overshoot the maximum lower travel of the vertical stage. This will be characterized by the stepper motor skipping steps which will make a clicking sound. If this happens, you must home the vertical axis and start the procedure again.

Film Thickness

The menu item Maintenance > Service > Film Thickness sets the vat film thickness. The vat film thickness is normally 0.12 mm.

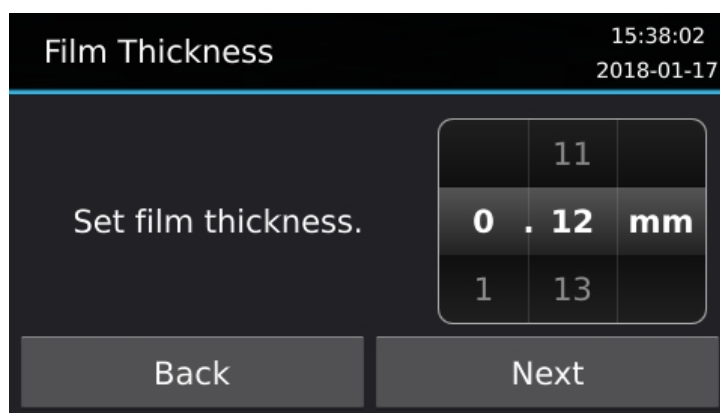

Calibration of the internal radiometer requires an external reference radiometer sensitive to light wavelengths in the range 350 nm to 450 nm. The image below shows a 3D printer system and an International Light ILT2400 Optical Meter. The person performing the calibration should wear UV safety glasses.

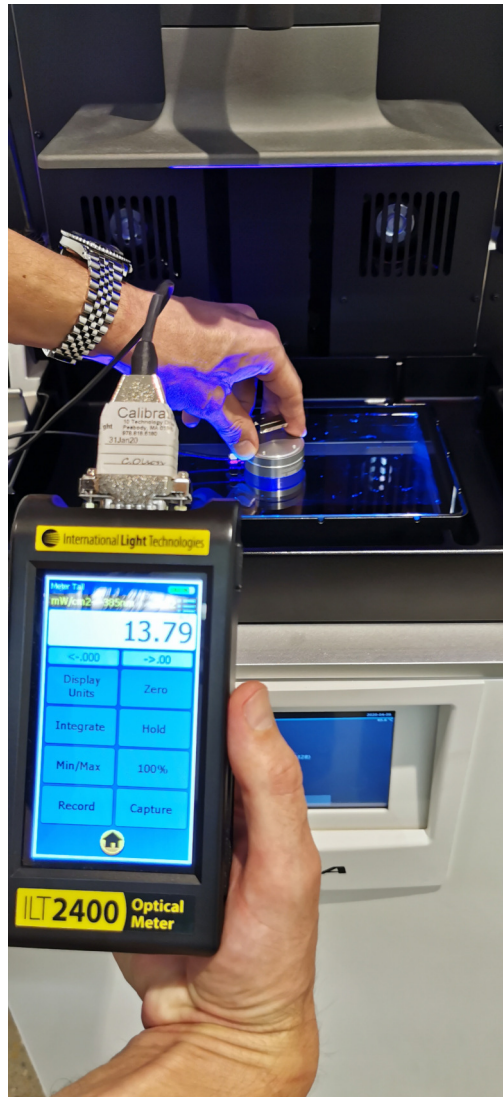

Calibrate Radiometer

To calibrate the PRO 4K internal radiometer:

1. Go to menu item Maintenance > Service > LED > Calibrate Radiometer. Click “Continue” at the warning screen.



2. Hold the radiometer head over the build aperture so that the sensor is in the build area.

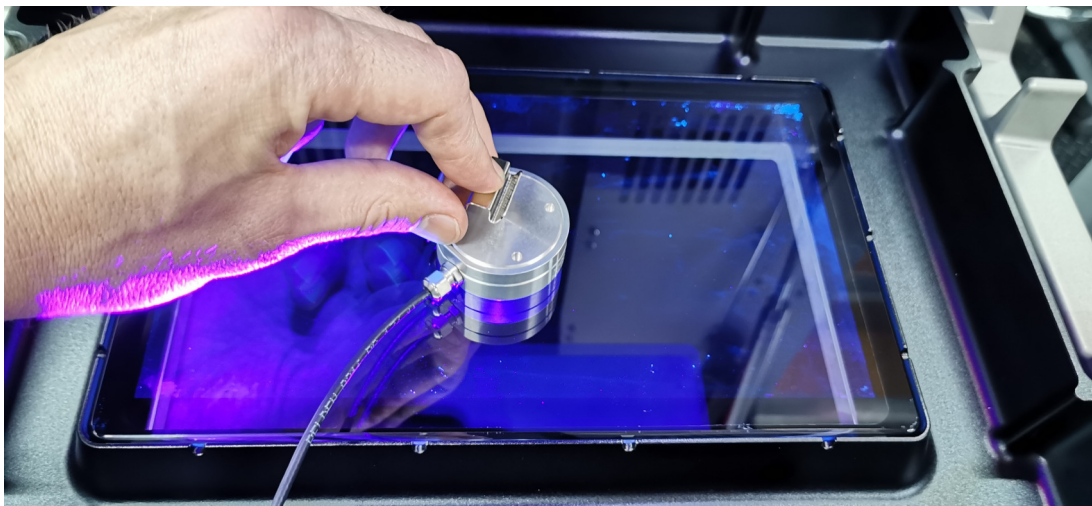

3. Note the value the external radiometer is reading. Ensure the wavelength setting of the radiometer corresponds to the LED wavelength of your PRO 4K.



4. Enter the value the external radiometer is reading in the menu and press "Next".

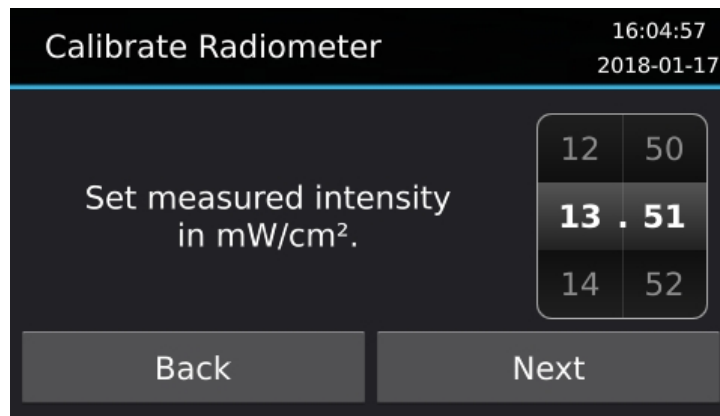

5. Press Yes to confirm the measured intensity.

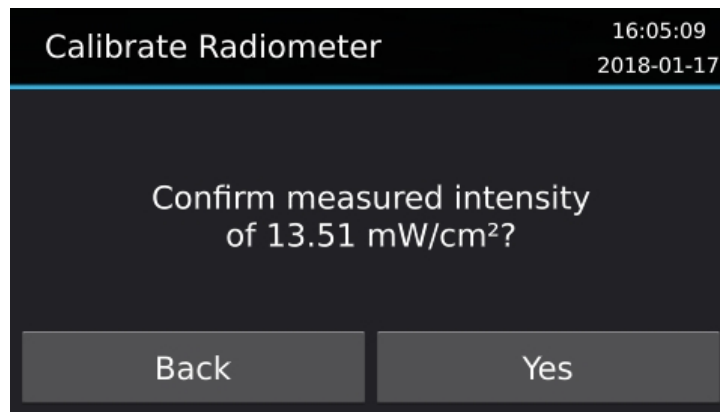

6. The internal radiometer will automatically be normalized to improve the radiometer response across the image area by illuminating different areas and measuring the change in radiometer readings. This will take less than 8 seconds to complete.

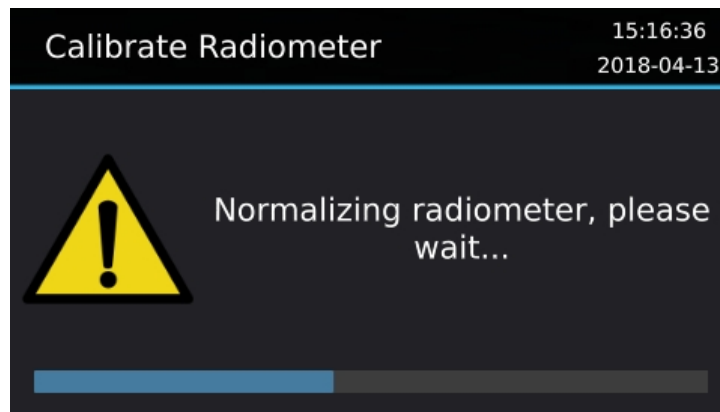

Normalize Radiometer

The Normalize Radiometer menu can be accessed by going to Maintenance > Service > Normalize Radiometer and is used to configure radiometer normalization.

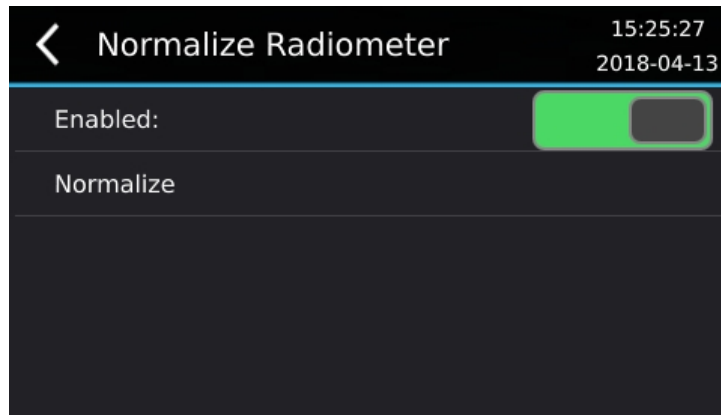

The Enabled toggle controls whether to use previously recorded normalization readings to improve the radiometer response across the image area. This does not need to be changed at all. It will be automatically enabled after performing the radiometer normalization process either automatically after Calibrate Radiometer is completed or manually normalizing by clicking Normalize.

To perform radiometer normalization:

1. Press Normalize
2. Ensure UV protective eyewear is worn and the build tray is removed.

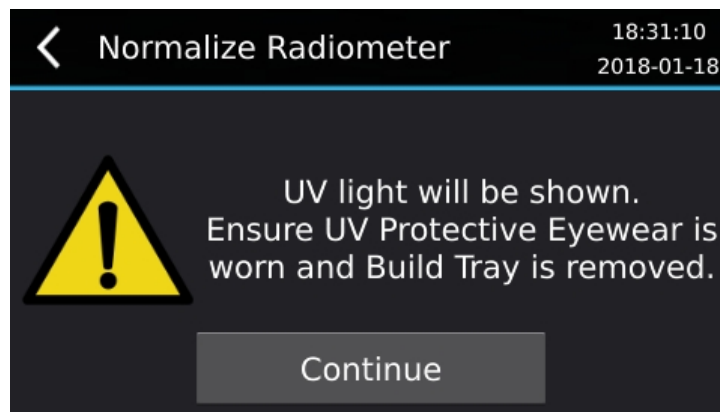

Press "Continue".

3. The internal radiometer will automatically be normalized to improve the radiometer response across the image area by illuminating different areas and measuring the change in radiometer readings. This will take less than 8 seconds to complete.

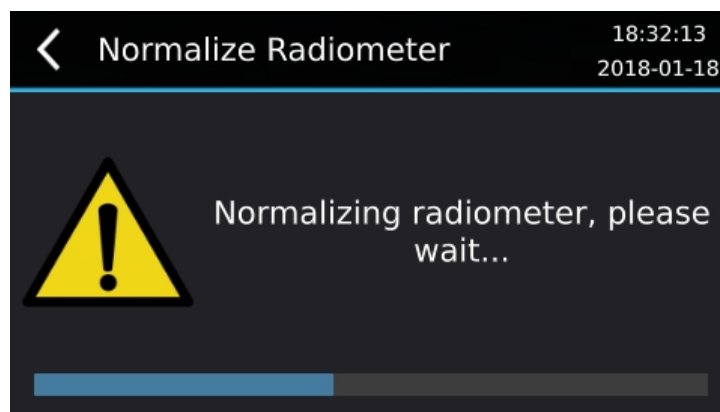

Calibrate Position Encoders

The PRO 4K uses four position encoders to measure pressure. These are calibrated at the factory and should not need to be recalibrated unless a position encoder been replaced.

1. Go to menu item Maintenance > Service > Position Encoders > Calibrate Position Encoders

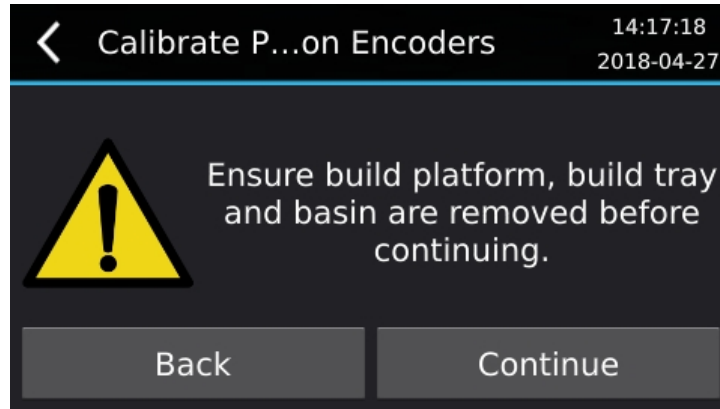

2. Remove build platform and build tray.

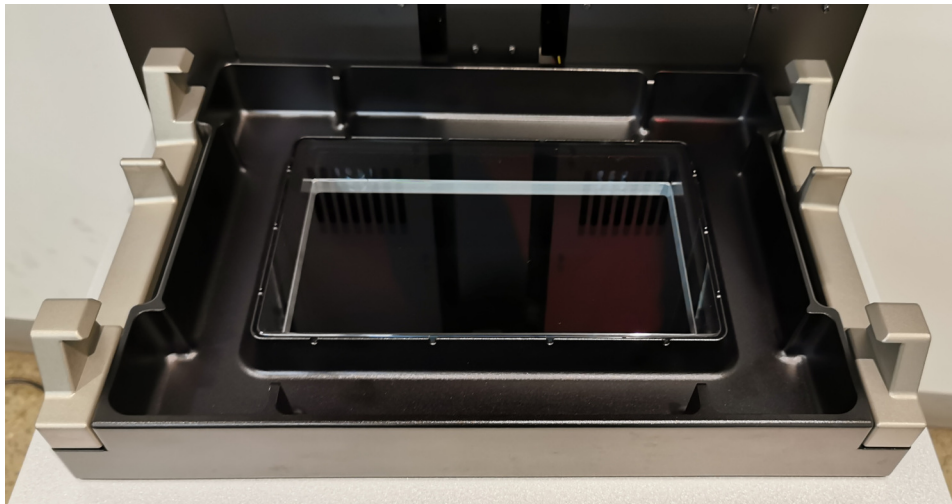

3. Remove the 4 black screws which hold the basin in place. Slide the vat latches to access them.



4. Remove the basin by lifting it with both hands and place it aside.



5. Press “Continue”.
6. Enter weight of the calibration object in kg and press “Next”.

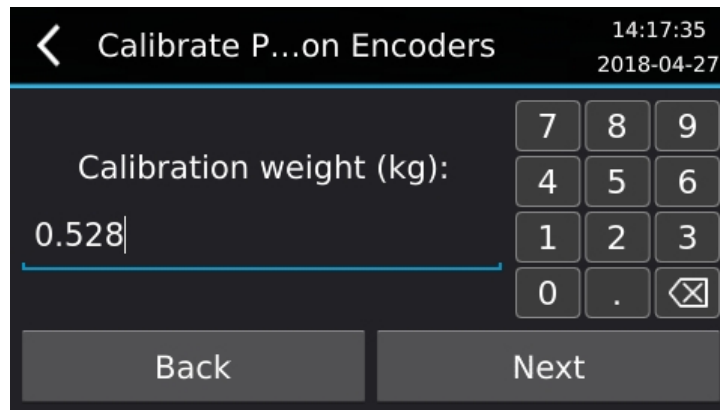
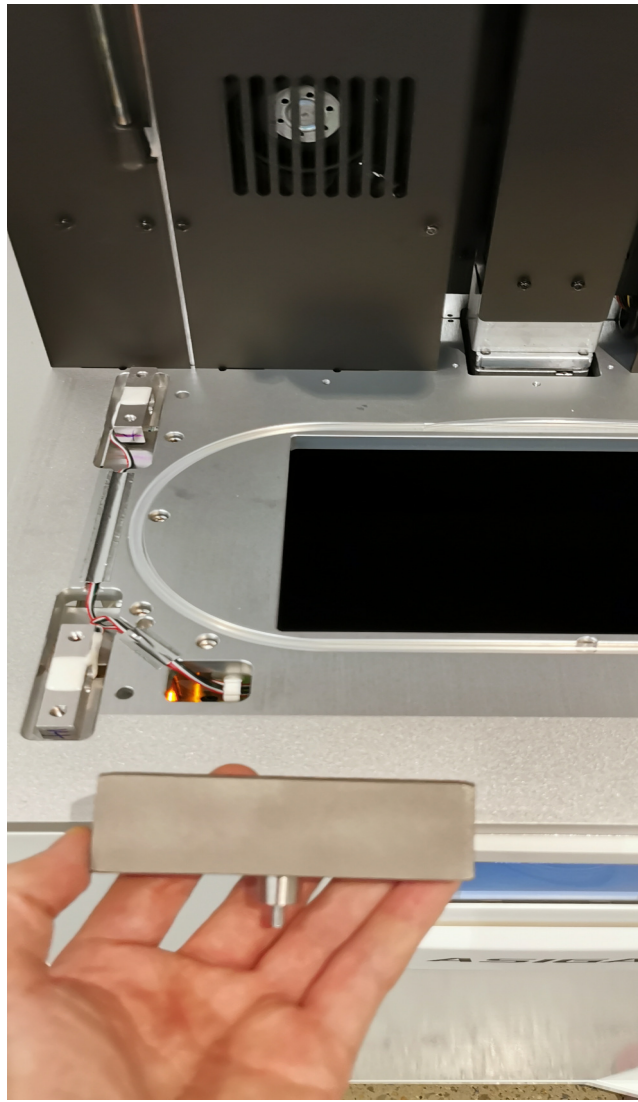

7. Place the calibration weight onto the front left position encoder (the calibration weight should only be touching the position encoder and not any other part of the machine). A square indicator is shown on the display for each position encoder. The indicator for the current position encoder will flash white.

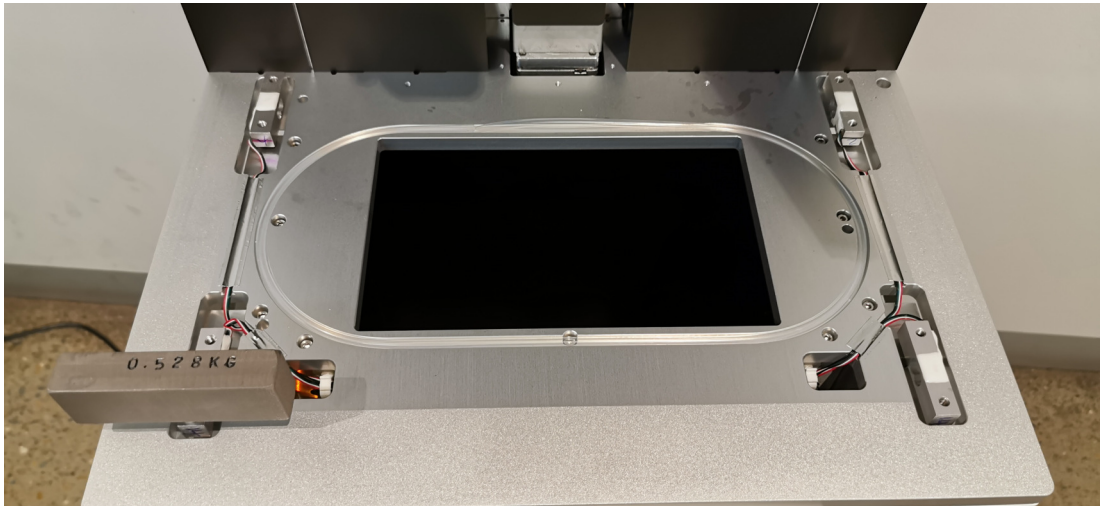
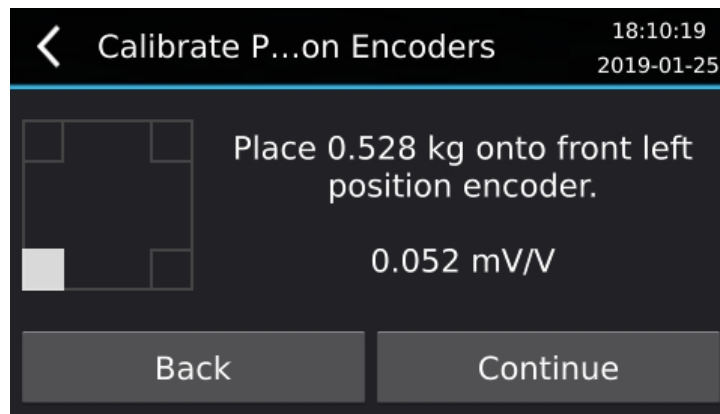

Once the calibration weight has been placed on the position encoder, the indicator should change to solid green.

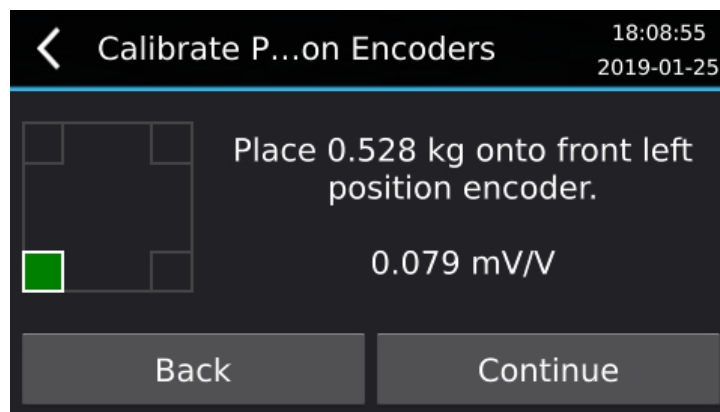

If the mV/V value has not increased enough, it will stay flashing white and pressing Continue will change the indicator to solid red to indicate the calibration for the position encoder has failed. Press Continue.

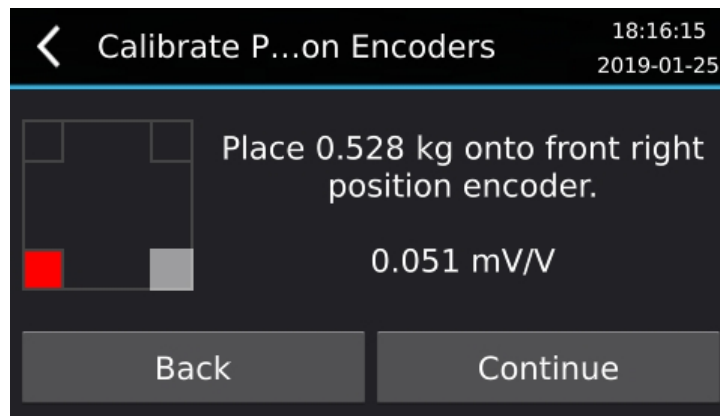

- Place the calibration weight onto the front right position encoder (the calibration weight should only be touching the position encoder and not any other part of the machine).

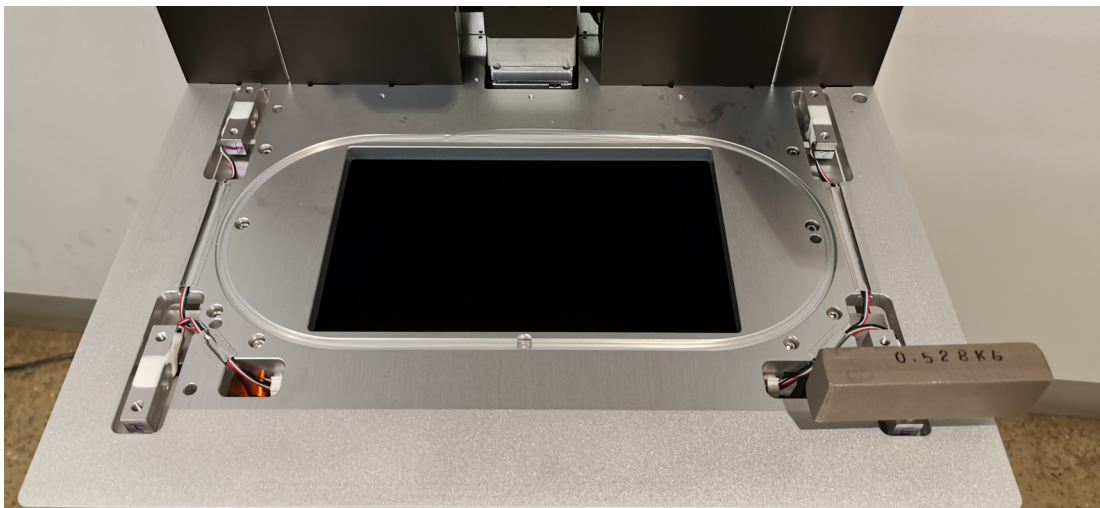
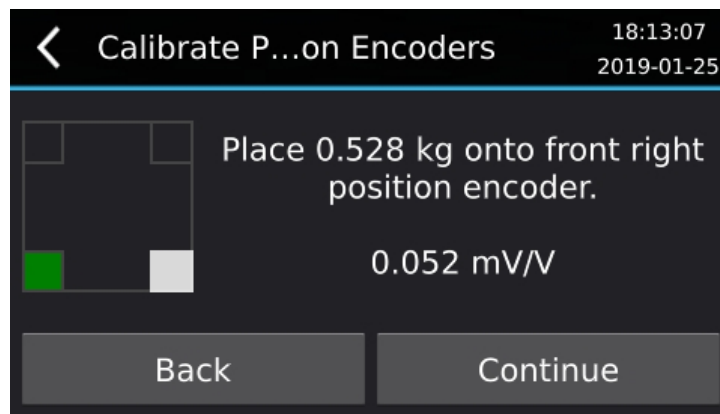

Once the calibration weight has been placed on the position encoder, the indicator should change to solid green.

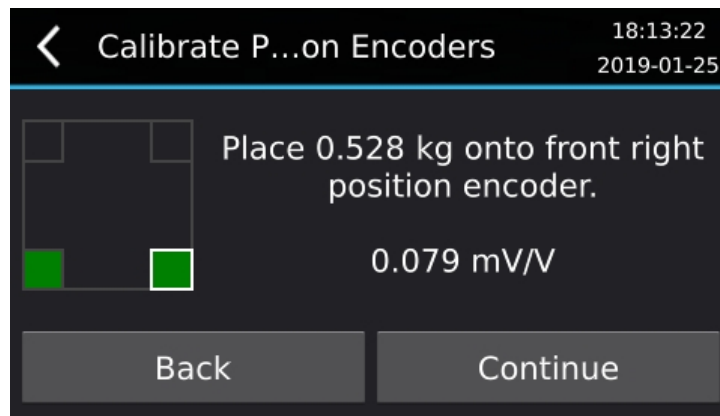

If the mV/V value has not increased enough, it will stay flashing white and pressing Continue will change the indicator to solid red to indicate the calibration for the position encoder has failed. Press Continue.

9. Place the calibration weight onto the back right position encoder (the calibration weight should only be touching the position encoder and not any other part of the machine).

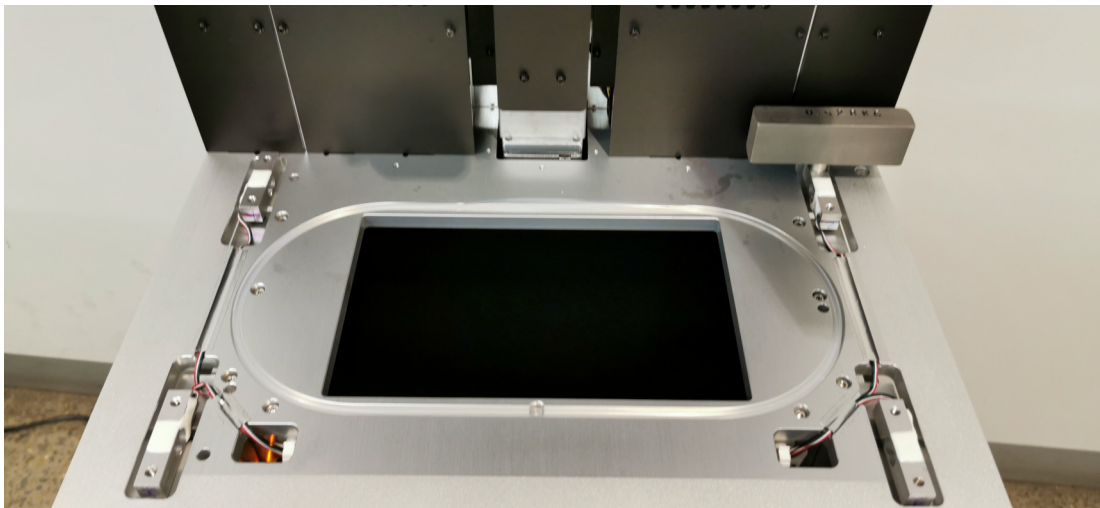
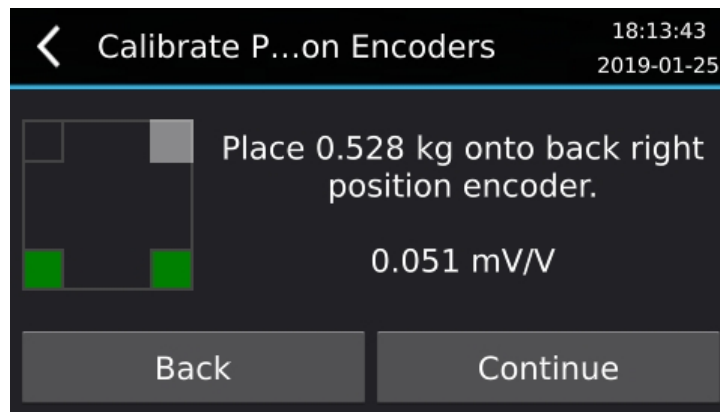

Once the calibration weight has been placed on the position encoder, the indicator should change to solid green.

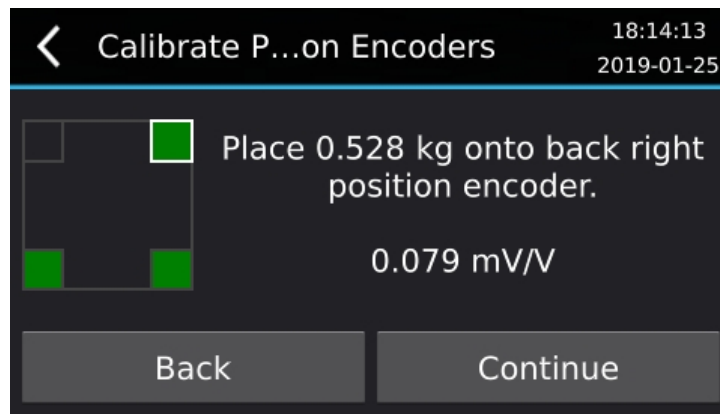

If the mV/V value has not increased enough, it will stay flashing white and pressing Continue will change the indicator to solid red to indicate the calibration for the position encoder has failed. Press Continue.

10. Place the calibration weight onto the back left position encoder (the calibration weight should only be touching the position encoder and not any other part of the machine).

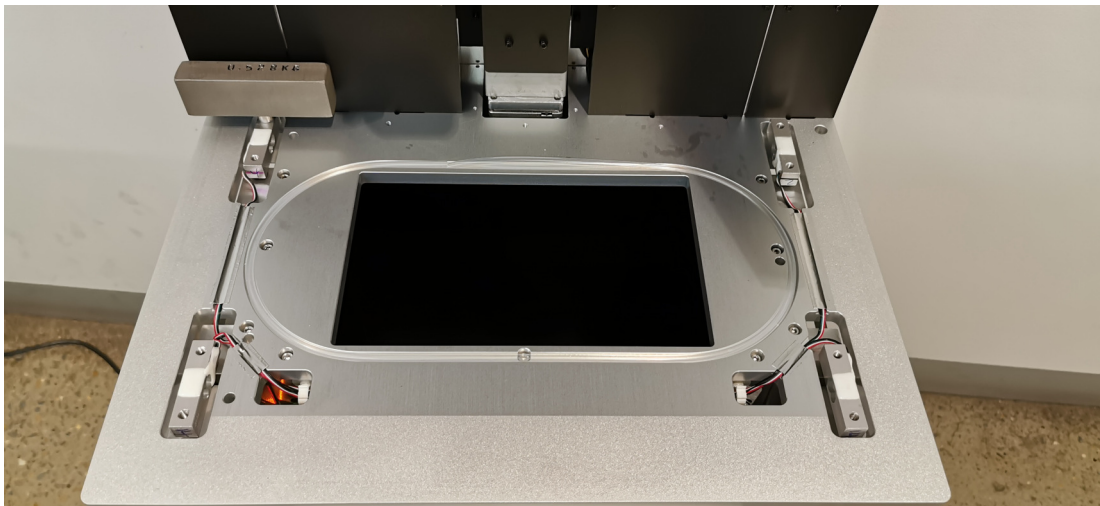
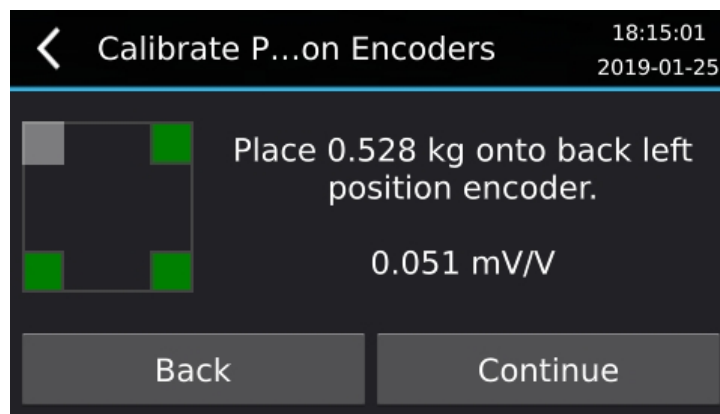

Once the calibration weight has been placed on the position encoder, the indicator should change to solid green.

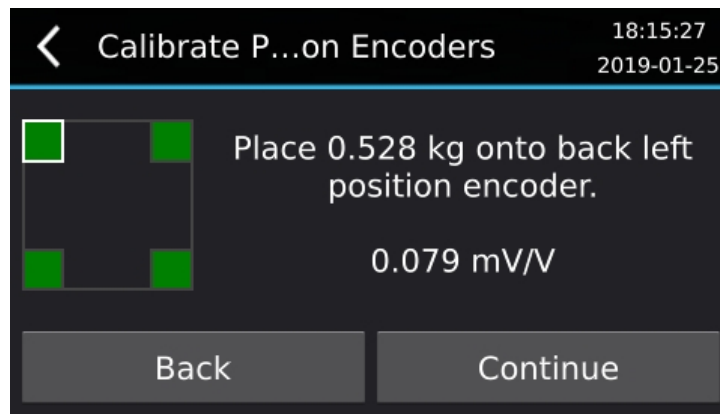

If the mV/V value has not increased enough, it will stay flashing white and pressing Continue will change the indicator to solid red to indicate the calibration for the position encoder has failed. Press Continue.

11. Remove the calibration weight. Ensure the silicon tubing is flat against the top plate.

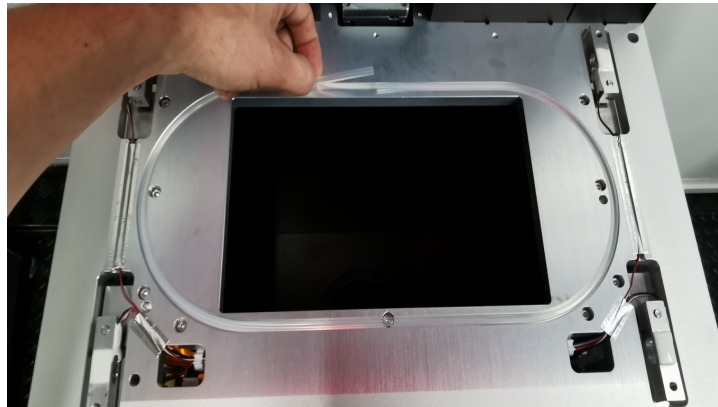

12. If all of the position encoders were successfully calibrated, all indicators will be green and you can proceed to reattach basin and tighten the 4 black screws which hold the basin in place. Do not insert the build tray. Press "Finish".

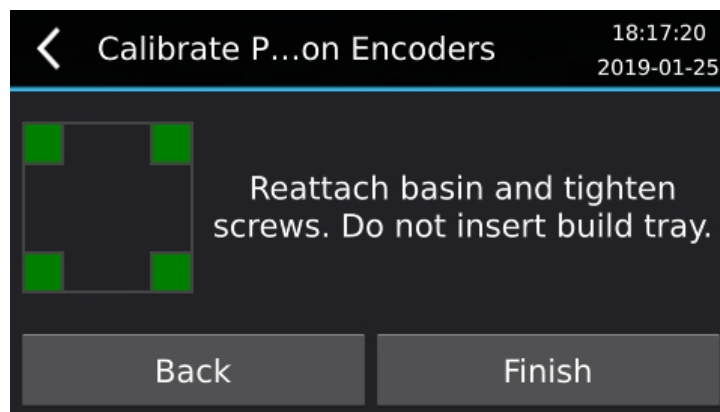

If calibration of one or more position encoders failed, then the screen will flash red with the indicators for the failed position encoders in red:

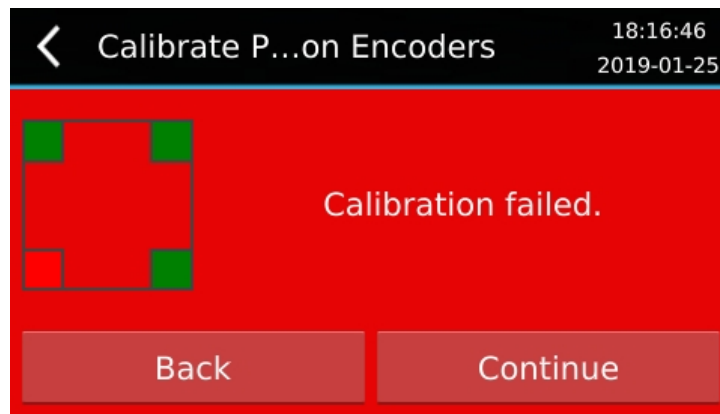

Press Back to go back to the previous screen or press the back arrow to go back to the menu. You may press Continue but the machine will not function correctly. After pressing Continue, reattach the basin and tighten the 4 black screws which hold the basin in place. Do not insert the build tray. Press "Finish".

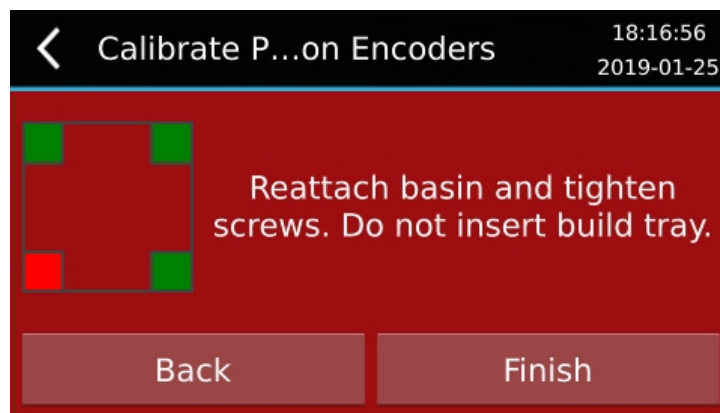

Calibrate Deflection

The PRO 4K uses four position encoders to measure deflection of the glass window. The deflection is calibrated as follows:

1. Go to menu item Maintenance > Service > Position Encoders > Calibrate Deflection.

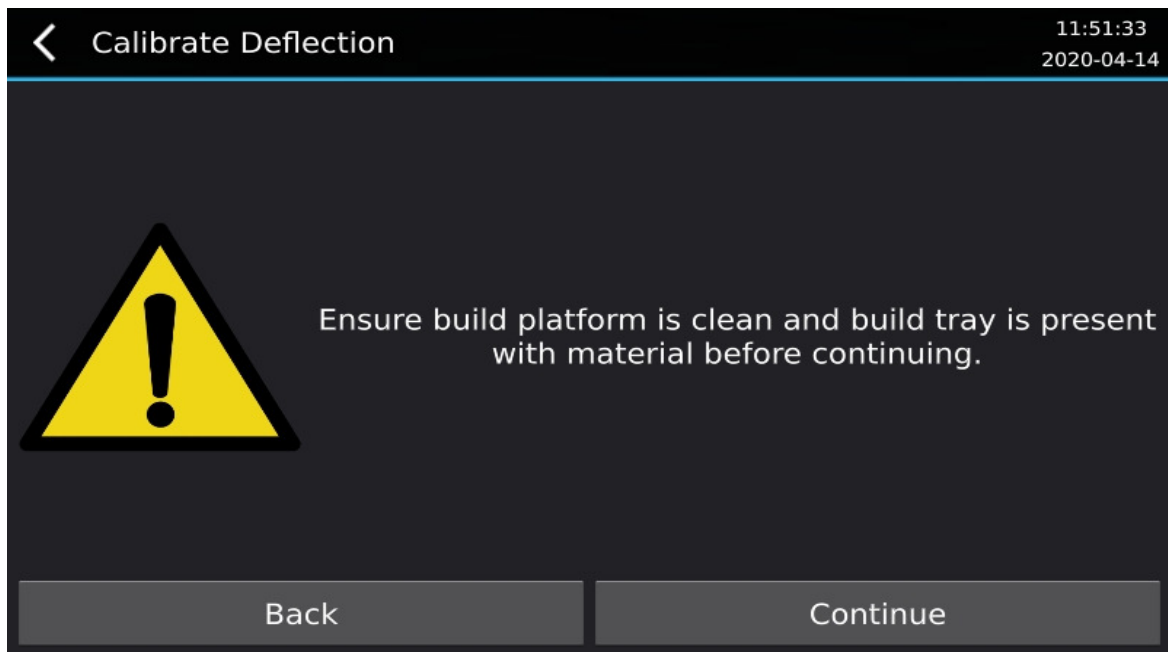

2. Install a clean build platform into the machine.
3. Install the resin vat with material into the machine.
4. Press "Continue".

The build platform will lower down into the material until a 0.1 mm gap is achieved and then show the LED for 60 seconds. The exposure will fill the gap between the platform and the tray film with solid resin. The build platform will then be pushed downward to measure the deflection.

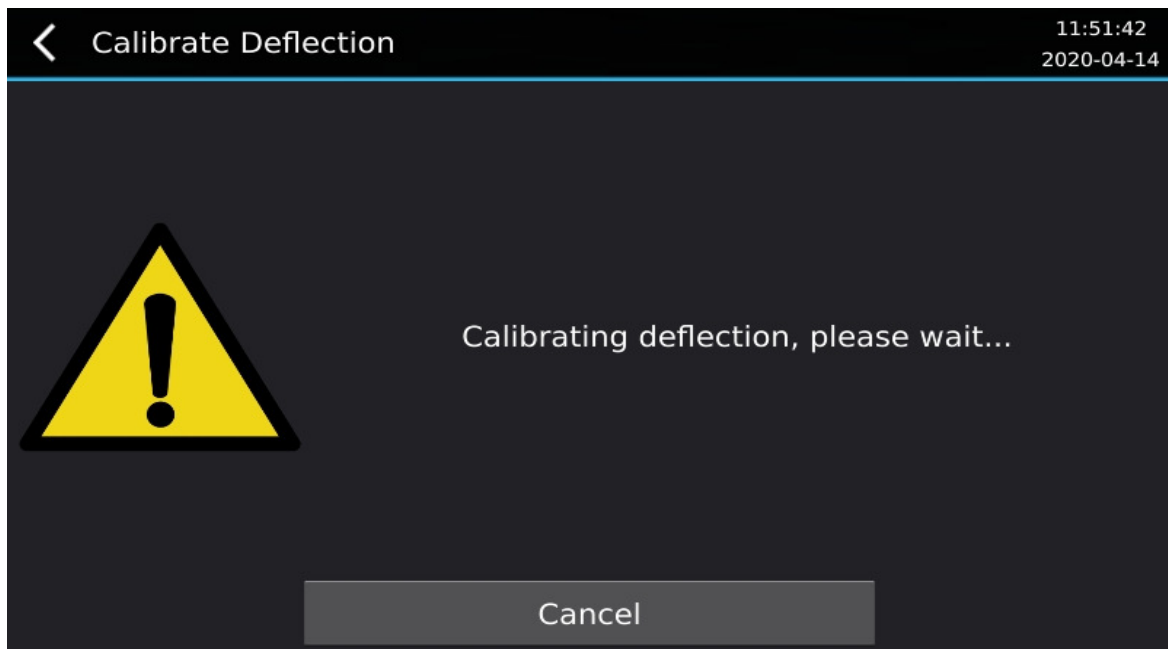

5. The process can be canceled at any time by pressing the "Cancel" button.
6. When the process is finished, you will be prompted to remove the exposed layer from the build platform.

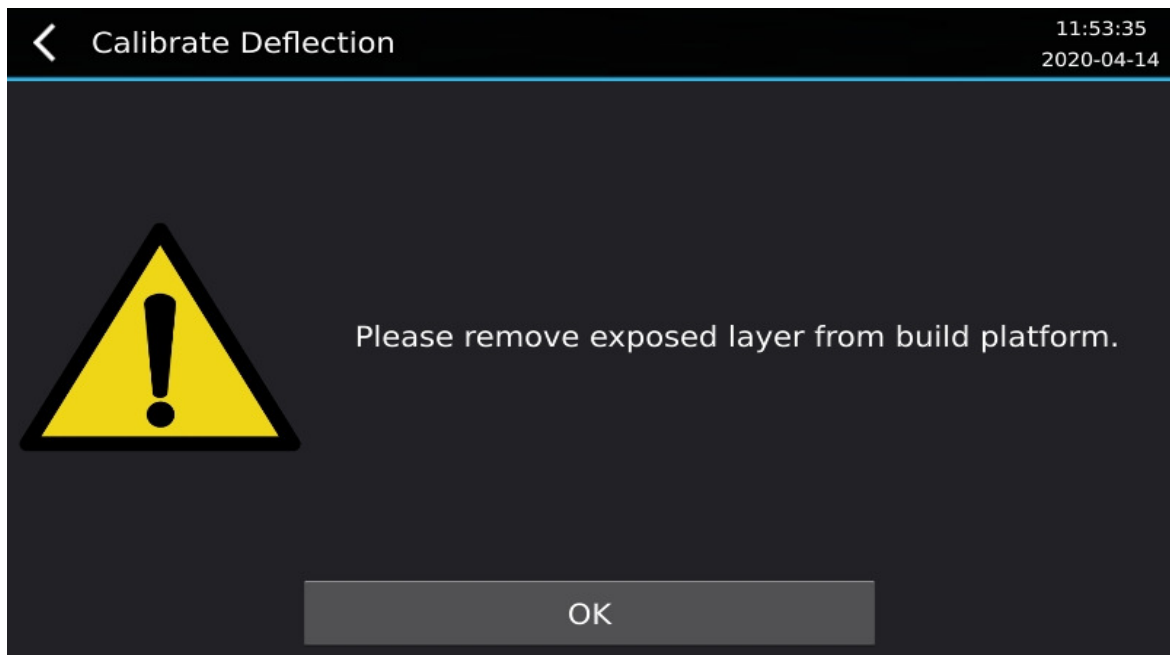

Remove the exposed layer from build platform and press OK when finished.

Detect Zero Position

Detect Zero Position is used to detect the height where the platform makes contact with the glass. It is normally run as part of Maintenance > Zero Position but can also be run manually.

1. Go to Maintenance > Service > Position Encoders > Detect Zero Position.
2. Ensure the platform platform is clean and build tray is removed.

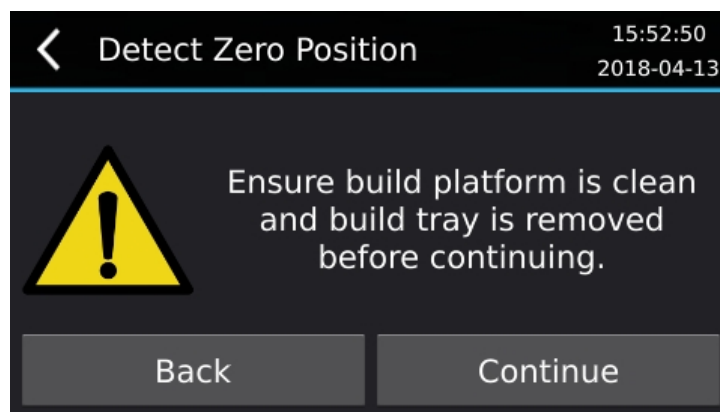

Press "Continue".

3. Set the calibration plate thickness. A calibration plate is a spacer placed underneath the build platform, if required, whose thickness is subtracted by the printer software if used. Normally no calibration plate is required, so a value of 0.00 mm can be selected.

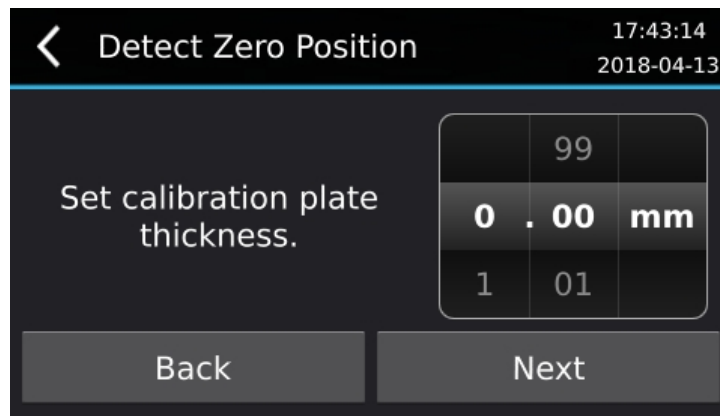

Press “Next”.

- The feedback from the position encoders is used to automatically detect the zero position of the build platform.

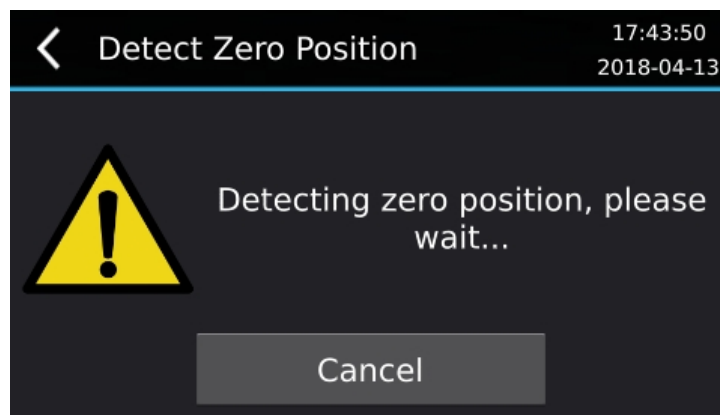

- After the process is finished, it will return back to the Maintenance > Service > Position Encoders menu.

Projector Calibration

The Projector Calibration menu may be used when a projector is replaced to load calibration data from the projector onto the system. It is accessed by going to Maintenance > Service > Projector Calibration.

The following warning will be shown when entering the Projector Calibration menu:

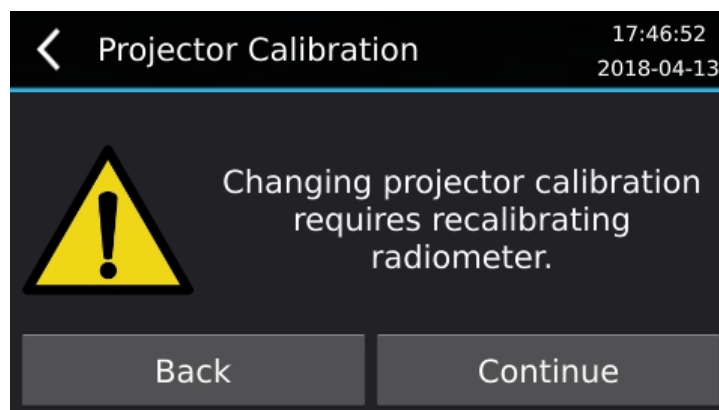

This means that after you load calibration or clear calibration, you will need to recalibrate the internal radiometer – please refer to Calibrate Radiometer in CHAPTER 8. Press “Continue” to proceed.

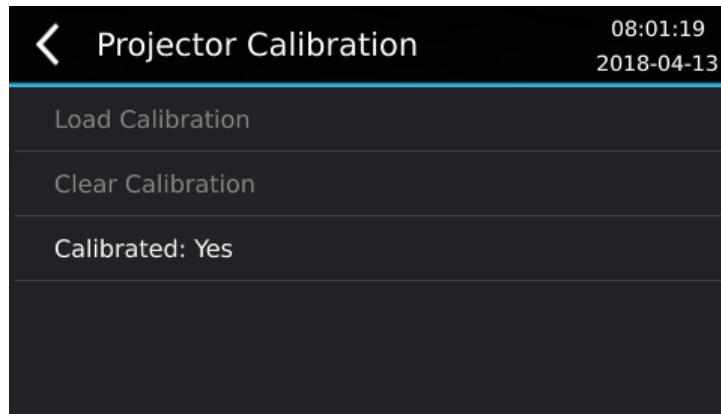

“Load Calibration” loads the calibration from a replacement projector onto your system. This option will only be enabled if there is calibration data available to load from the projector.

“Clear Calibration” clears the projector calibration from your system. This will only be enabled if projector calibration data is present on the system and also if calibration data is available to load from the projector. This is to make sure it is always possible to restore the system to a calibrated state after clearing the calibration from the system.

The last item indicates whether projector calibration data is loaded onto the system.

Touch Screen

The Touch Screen menu is used for calibrating the touch screen. It is accessed by going to Maintenance > Service > Touch Screen.

The default touch screen calibration is normally sufficient and updating the calibration is rarely required. Incorrect touch screen calibration can result in being unable to use the touch screen and the system being usable only through the Front Panel tab of the web interface.

Ensure that you are able to access the web interface before proceeding in case the touch screen becomes unusable after incorrect calibration.

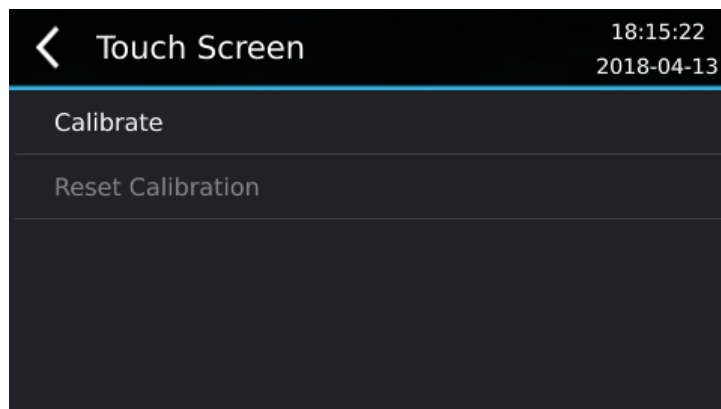

To calibrate the touch screen:

1. Ensure you have a resistive touchscreen stylus.
2. Press “Calibrate”.

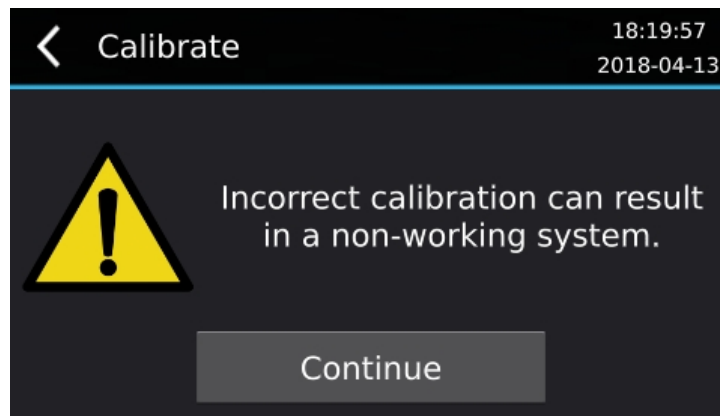

3. Press “Continue” and follow the on-screen instructions by using the stylus to touch the screen at the requested positions. Make sure you don’t accidentally tap the same position twice.
4. If you are confident that you did the calibration correctly then press “Yes”, otherwise “No” to cancel.

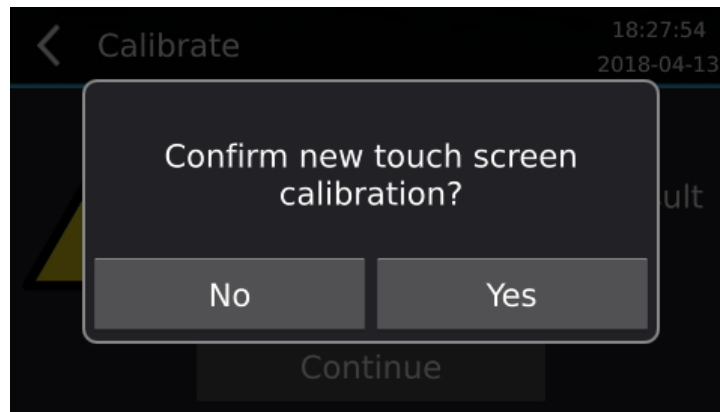

After pressing “Yes”, the system will restart and the new touch screen calibration will take effect.

To reset the touch screen calibration:

1. Press “Reset Calibration”.

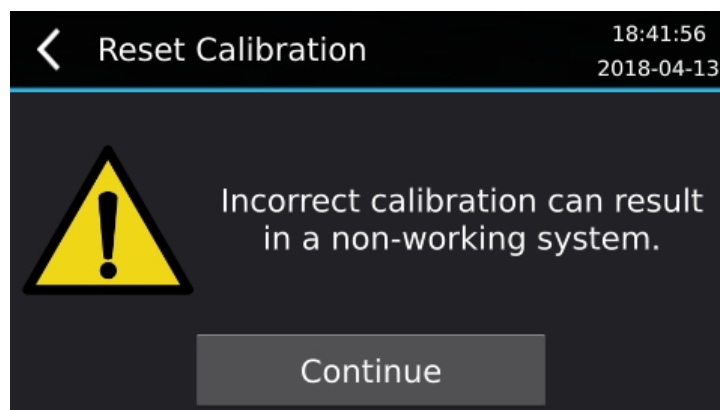

2. Press “Yes” to proceed or “No” to cancel.

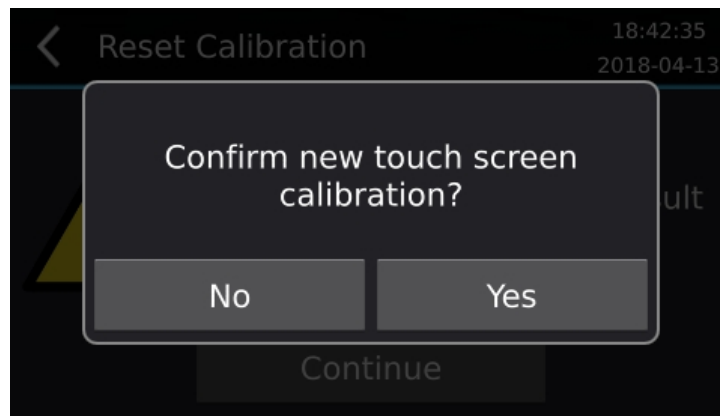

After pressing “Yes”, the system will restart and the new touch screen calibration will take effect.