

New as of:

10.2015

SIROLaser Blue

Operating Instructions

English



Table of contents

1	General information	6
1.1	Dear Customer	6
1.2	Contact data	6
1.3	General information on the Operating Instructions	7
1.4	Intended use	7
1.5	Formats and symbols used	8
2	Safety information	9
2.1	Identification of danger levels	9
2.2	Standards and regulations	9
2.3	Operating personnel	9
2.4	Physical working principle	10
2.5	Laser radiation hazards	10
2.6	Nominal ocular hazard distance	11
2.7	Laser protective goggles	11
2.8	EasyTips and MultiTips	12
2.9	Contamination	12
2.10	Installation	13
2.11	Modifications	14
2.12	Cellular phones	14
2.13	Transferring data with usb stick	14
3	System description	15
3.1	System overview	15
3.2	Laser operation modes	17
3.3	Symbols and abbreviations	18
3.3.1	Symbols	18
3.3.2	Abbreviations	20
3.4	Technical Data	21
4	Installation	25
4.1	Scope of supply	25
4.2	Spare parts	26
4.3	Labels	26

4.4	Initial start-up – procedure for proper assembly	27
4.4.1	Install power supply	27
4.4.2	Handpiece and assembly of single-use fiber tips and therapy rods .	28
4.4.2.1	Handpiece	28
4.4.2.2	Assembly of sterile single-use optical fiber tips	28
4.4.2.3	Assembly of therapy light guides.....	32
4.4.3	Install wireless foot control – optional.....	34
4.4.4	Install remote interlock – optional	35
5	Operation.....	36
5.1	Start the device for the first time	36
5.2	Switch on/off power	38
5.3	Enter pin code	39
5.4	Sleep Mode	39
5.5	Main home screen.....	39
5.5.1	Self Test	40
5.5.2	Favorites	42
5.5.3	Submenu: All applications	42
5.5.3.1	My Applications	46
5.5.3.2	Settings	46
5.5.4	Error messages, warnings and instructions	53
5.5.4.1	Error messages and warnings.....	53
5.5.4.2	Instructions	55
5.5.4.3	Information messages	56
6	Indications, contraindications and medical precautions	57
6.1	Indications	57
6.2	List of preset indications.....	57
6.3	Further non-preset indications	59
6.4	Examples of treatment risk.....	60
6.5	Contraindications	60
7	Cleaning, disinfection and sterilization	61
7.1	Cleaning	61
7.2	Disinfection.....	62
7.3	Sterilization.....	62
7.4	Cleaning the control unit	63
8	Maintenance and service	64
8.1	Safety checks	64
8.2	Maintenance.....	64

8.3	Troubleshooting of simple defects.....	65
8.4	Technical support, repair and testing	66
8.5	Replacing the rechargeable battery of the control unit.....	67
8.6	Replacing the batteries of the wireless foot control.....	68
8.7	Replacement of parts subject to wear and tear	69
9	Electromagnetic compatibility	70
9.1	Electromagnetic emission	70
9.2	Interference immunity.....	71
9.3	Working clearances.....	73
10	Disposal.....	74
10.1	Batteries	75
10.2	Accessories	75
11	Appendix.....	76
11.1	Appendix A – Certification	76
11.2	Appendix B -Label positions.....	76
	11.2.1 Control unit.....	76
	11.2.2 Wireless foot control – optional	77
11.3	Appendix C – Safety circuit (interlock).....	78

1 General information

1.1 Dear Customer

We are pleased that you have equipped your practice with the SIROLaser Blue.

You now possess a therapy device that features diode laser technology. This device is characterized by a wide range of applications. It can be used as rather pain-free therapy or as an extension to the conventional treatment. A high number of therapies are already preset. According to your approach you can change settings or put on also own treatment programs. The laser can alternatively be activated by the finger switch at the handpiece or by the optional wireless foot switch.

These Operating Instructions are designed to assist you prior to initial use and whenever you require information later on. It is important to observe all safety information to prevent personal injury and material damage. Please perform maintenance and cleaning based on the corresponding instructions.

We wish you much success and pleasure with the SIROLaser Blue.

Your SIROLaser Blue Team

1.2 Contact data

Customer service center

In the event of technical queries, please use our online contact form at www.sirona.com. In the navigation bar, go to the menu commands *"CONTACT" / "Customer Service Center"* and then click the *"CONTACT FORM FOR TECHNICAL QUESTIONS"* button.

Manufacturer's address

Sirona Dental Systems GmbH
Fabrikstrasse 31
64625 Bensheim
Germany

Phone: +49 (0) 6251/16-0
Fax: +49 (0) 6251/16-2591
e-mail: contact@sirona.com
www.sirona.com



1.3 General information on the Operating Instructions

Observe the Operating Instructions

Please familiarize yourself with the SIROLaser Blue by reading through these Operating Instructions before putting it into operation. It is essential that you comply with the specified warning and safety information.

WARNING

Do not use the device in the case when it shows a behaviour different to the operating instructions.

Keep documents safe

Always keep the Operating Instructions handy in case you or another user require(s) information at a later point of time. To this product belong even more documentations.

In case you sell the unit, make sure that the Operating Instructions and all other technical documents are attached to it so that its new owner can familiarize himself with its functioning and the specified warning and safety information. The technical documents are a component of the product.

Help

If you reach an impasse despite having thoroughly studied the Operating Instructions, please contact your dental dealer.

1.4 Intended use

The SIROLaser Blue is developed as a table top laser device for:

- Soft-tissue surgery with simultaneous coagulation
- Germ reduction in endodontics
- Germ reduction in periodontology and implantology
- Low level laser therapy for the following: dentine-hypersensitivity and wound healing
- Treatment of aphthous ulcers and herpes
- Desensitization

All patients coming to a dental office or clinic and needing a treatment that can be done or supported by the use of a diode laser can be treated with the SIROLaser Blue. For indications for use refer to chapter "Indications, contraindications and medical precautions [→ 57]".

The use of the SIROLaser Blue is not appropriate in an operating theater.

1.5 Formats and symbols used

The symbols and character formats used in the present manual have the following meaning:

Instructions for action

<ul style="list-style-type: none"> ✓ Prerequisite 1. First action step 2. Second action step or <li style="padding-left: 20px;">➤ Alternative action ↔ Result, reaction of SIROLaser Blue 	Prompts you to do something.
---	------------------------------

References

See "General information [→ 6]"	Identifies a reference to another text passage.
[→ 8]	Indicates the page being referred to.

Lists

• List	Designates a list.
--------	--------------------

Designations

'Designation'	Denotes key and button
---------------	------------------------

2 Safety information

2.1 Identification of danger levels

To prevent personal injury and material damage, please observe the warning and safety information provided in this document. Such information is highlighted as follows:

WARNING

Warning of bodily injury

For a possible danger that could result in light to serious bodily injury or death.

CAUTION

Caution against damage

For a possibly harmful situation which could lead to damage of the product or an object in its environment.

NOTICE

Information to make work easier

For application information and other useful information.

2.2 Standards and regulations

For the installation and operation of the SIROLaser Blue, Sirona Dental Systems GmbH requires:

- compliance with IEC 60825-1 and its amendments,
- observance of any supplemental national laws and regulations.

Public legal requirements may include special safety regulations concerning protection against laser radiation. These requirements must be fulfilled.

The SIROLaser Blue is manufactured in compliance with the provisions of Council Directive 93/42/EEC (MDD) concerning medical devices.

National directives regarding electrical installations must be observed.

2.3 Operating personnel

Qualification/education

The SIROLaser Blue may only be operated by educated and qualified personnel (dentist, assistant, dental hygienist). The applicable occupational safety regulations and accident prevention measures, the current operating instructions and national requirements concerning education must be complied with.

Know-how

Know-how and expertise about laser therapy as well as the skilled use of the laser and the applied indications are required. Please refer to applicable country-specific requirements.

Experience

Sirona recommends to gain practical experience in laser dentistry before first use of the SIROLaser Blue by attending an appropriate training.

Amongst others Sirona offers trainings. Please see the Sirona homepage (www.sirona.com).

Obligation of the user

Users are obliged to use only faultless materials, to ensure correct application and to protect themselves, the patient and other persons against hazards.

Unauthorized access

In order to prevent false or improper use, the SIROLaser Blue must not be used by unauthorized persons. Therefore the SIROLaser Blue equipment must be protected against unauthorized access when not in use. This can be achieved, for example, by switching the SIROLaser Blue off after usage so that the electronic access key (pin code) must be entered before using it again.

WARNING

The SIROLaser Blue may only be used and maintained by thoroughly trained personnel.

2.4 Physical working principle

The 445 nm, 970 nm and 660 nm laser radiation of the SIROLaser Blue is generated via different laser diodes inside the control unit and guided to the treatment region via quartz fibers. The laser radiation is absorbed by the tissue and converted to heat used for cutting, coagulation, germ reduction and desensitization.

2.5 Laser radiation hazards

Never direct the laser or aiming beam toward a person's eye! All persons present in the room e.g. patient, dentist and assistant must always wear the laser protective goggles.

Observe all labels on the SIROLaser Blue.

Master switch of the practice

Note that after switching off the master switch of the practice the SIROLaser Blue will still remain switched on. It is then energized by the rechargeable battery.

Emergency stop

In case of an emergency press the "Laser Stop" button below the touch screen on the front side of the SIROLaser Blue control unit.

Settings

Failure to use the settings specified in this manual or perform the actions described here may lead to a dangerous exposure to radiation.

Sirona Dental Systems GmbH cannot be held liable for any damage caused by improper use or non-compliance with the instructions and information provided in this manual.

Flammable materials

Never direct the laser beam towards any flammable material, e.g. paper or plastics. They could catch fire due to the high temperatures produced by the laser beam.

The unit is not suitable for use in the presence of anesthetics that are flammable when in contact with air, oxygen or nitrogen monoxide.

Oxygen-saturated materials such as cotton wool can catch fire owing to the high temperature that the unit reaches during operation. Label removers and flammable solutions used for cleaning and disinfecting the SIROLaser Blue should be allowed to evaporate before using the device. Observe fire hazards caused by flammable gases.

Reducing the risk of burns

If any tissue is unintentionally irradiated, this may lead to burns. This risk can be reduced by surrounding the target area with moistened sterile drapes or gauze doused in salt. These covering materials must meet the requirements of laser surgery.

2.6 Nominal ocular hazard distance

The nominal ocular hazard distance (NOHD) from the distal end of the optical fiber is 1.5 m.

2.7 Laser protective goggles

All persons present in the room e.g. patient, dentist, assistant must always wear the appropriate laser protective goggles delivered along with the SIROLaser Blue.

Check before use

Before using the laser protective goggles, please read and observe the instructions for use provided by the manufacturer and attached to the goggles in the case. Make sure that the laser protective goggles:

- are not damaged
- conform to standard EN 207 with the following protection levels:
 - user goggles: LB5 (445 ± 5 nm / 970 -10/+15 nm) and LB1 (660 ± 5 nm)
 - patient goggles: LB5 (445 ± 5 nm / 970 -10/+15 nm) and LB3 (660 ± 5 nm)
- are suitable for the correct wavelengths (labeled on the goggles)

These instructions apply particularly when using goggles supplied from an outside source that are not included in the scope of delivery of the SIROLaser Blue.

Optical instruments

Never use optical instruments such as microscopes, eye loupes or magnifiers together with the original protective goggles. Otherwise sufficient eye protection can no longer be ensured.

2.8 EasyTips and MultiTips

Optical fiber tips and connection socket

Make sure that no dust, dirt and foreign particles can enter the optical fiber socket or the optical system. Never place your finger or any other objects in the optical connectors. Otherwise the unit may be permanently damaged.

When disconnecting the EasyTip or MultiTip from the SIROLaser Blue, always cover the connection socket at the handpiece with the special protection cap supplied. Make sure that the optical system is clean before connecting the EasyTip or MultiTip.

The optical fiber must not be twisted inside the tube of the single-use fiber tip (EasyTip). There is a risk of breakage.

Stop the laser activation of the SIROLaser Blue immediately if the EasyTip or MultiTip is broken. Otherwise the tips may become hot.

EasyTips and MultiTips must be checked for sure seating prior to each use.

WARNING

Single-use fiber tips (EasyTip) must not be sterilized again after usage. They are disposable products.

2.9 Contamination

Accessories

Danger of (cross) contamination. Pay attention not to hurt or stick yourself or any other person with the laser fiber tip. This applies also, if the handpiece is placed in the holder.

Prior to each use, the handpiece sleeve and the optical light guide (MultiTip) must be sterilized. The single-use fiber tips are delivered sterile and must be used only once.

Tissue particles

By cutting and coagulation of tissue, tissue particles could get into the air. Always wear a face mask, because a risk of infection exists.

A extractor or a filter should be used. The operating personnel should be aware that biologically active material could get into the environment. It may contain particles of viable tissue.

WARNING

Single-use fiber tips (EasyTip) must not be sterilized again after usage. They are disposable products.

2.10 Installation

Location

The SIROLaser Blue is to be protected against the intrusion of liquids.

The SIROLaser Blue must not be used in areas, in which the appearance of liquids is probable.

Verify that the line voltage corresponds to the voltage indicated on the rating plate of the power supply or in the technical specifications.

Do not place the unit near heat sources. Do not cover the convection openings for air cooling on the sides of the unit.

Make sure that the electrical system is equipped with the required devices for protection against direct and indirect contact (thermomagnetic switches, residual current circuit breakers) and has been set up by a qualified electrician in compliance with the applicable standards.

Avoid interference between the laser emission and any optical sensors of devices operated in the vicinity of the SIROLaser Blue.

National directives regarding electrical installations must be observed.

Set up

Set up the SIROLaser Blue unit properly and completely before putting it into operation, see chapter "Installation [→ 25]".

Functional Check

The system owner is obliged to use only technically faultless products. Please check the unit for proper functioning before putting it into operation. In case of unusual noises, check both the unit and the handpiece. If the unit has fallen down, have it checked by qualified technical personnel.

To prevent the unit being accidentally pulled from the table, the handpiece hose should never be under tension. Please always ensure that ca. 40 cm of the handpiece hose hangs.

If there is any doubt about the correct function of the switching power supply or the correct electric power supply (wall outlet) the unit may only be used with internal electric power supply (battery).

Do not use the SIROLaser Blue if a visual inspection shows that it has been damaged.

2.11 Modifications

General product safety

As manufacturers of dental medical equipment and in the interest of the operational safety of your system, we stress the importance of having maintenance and repair of this product performed only by Sirona Dental Systems GmbH or by agencies expressly authorized by us. Furthermore components must always be replaced with original Sirona spare parts upon failure. When having such work done, we suggest that you request a certificate stating the type and extent of work performed, including information about any modifications of the rated parameters or of the operating ranges (if applicable), as well as the date, name of organization and signature. Please use a fault circuit interrupter to connect this system to the electrical line power supply. Modifications to this system which might affect the safety of the system owner, patients or other persons are prohibited by law! For reasons of product safety, this product may be operated only with original Sirona accessories or third-party accessories expressly approved by Sirona. The user is responsible for any damage resulting from the use of non-approved accessories.

It is not permitted to modify the design or construction of the unit.

Maintenance

The unit must be checked and maintained at regular intervals, as described in chapter "Maintenance and service [→ 64]".

Damages

If you accidentally spill any liquid on the unit, immediately stop treatment, disconnect the power cable and contact your local dental dealer or your authorized service center for assistance.

Never under any circumstances try to disassemble the SIROLaser Blue. This is limited exclusively to trained and authorized personnel.

2.12 Cellular phones

Portable and mobile RF communications equipment may interfere with medical electrical equipment. Therefore, the use of mobile wireless phones in medical office or hospital environments must be prohibited.

2.13 Transferring data with usb stick

To guarantee the correct datatransfer for software update or storage of the history file use always an USB-Stick with the following specification:

- USB class 2.0 or above
- Minimum capacity of 512 MB
- Filesystem FAT32 or NTFS

Always perform the datatransfer according to the instructions of the manual. Never disconnect the USB-stick during data transfer while you perform a software update or the storage of the history file.

The connection of the SIROLaser to other USB-devices could result in previously unidentified risks for your patients, yourself or others.

3 System description

3.1 System overview

SIROLaser Blue (Control unit)



A	LED lights
B	Touch screen
C	Laser Stop key
D	Carry handle
E	Single-use fiber tips (EasyTip)
F	Finger switch with exchangeable keypad
G	Metal handpiece sleeve
H	Snap tab
I	Cable for optical fiber and wires

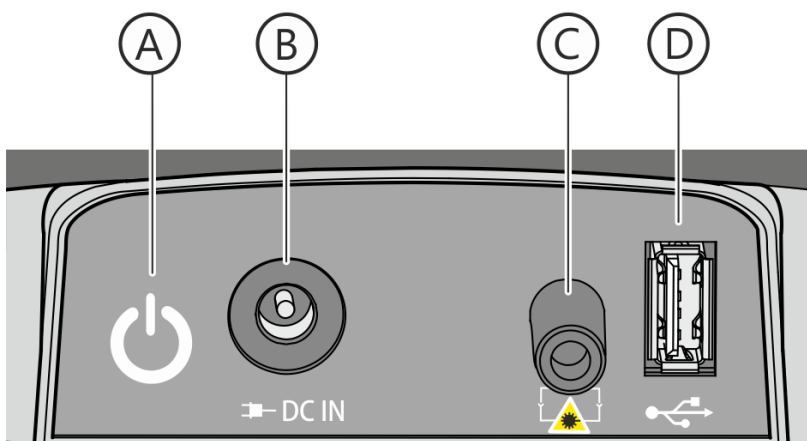

A	ON/OFF switch
B	Power supply socket
C	Interlock connector including interlock connector bridge
D	USB port

Wireless foot control – optional

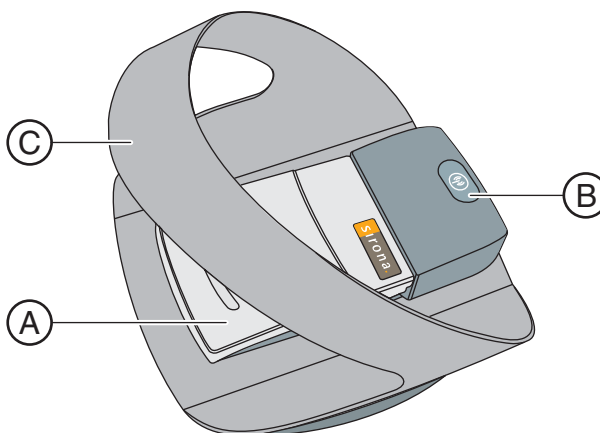

A	Foot switch
B	Registration key
C	Safety and positioning bar

3.2 Laser operation modes

Continuous wave mode (CW)

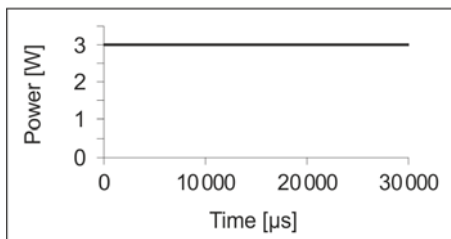

CW implies a continuous, uninterrupted laser beam as long as the laser is activated (and determined by a time set). This means a very good power control since the maximum power equals the average power.

In adjacent example the laser is in CW mode with a power of 3 W.

Chopped mode

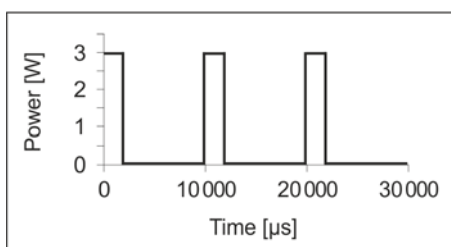

in literature sometimes also called "pulse mode"

The laser beam is interrupted at regular intervals (e.g. 50% ON and 50% OFF) which can be adjusted via the duty cycle. The average power is the product of power and duty cycle.

The result is a better thermal control due to the fact that the OFF periods are used for thermal relaxation of the tissue.

In adjacent example the laser is in chopped mode with a power of 3 W and a duty cycle of 20%. The average power is 0.6 W.

3.3 Symbols and abbreviations

3.3.1 Symbols



Type B applied part according to IEC 60601-1



CE mark in accordance with Council Directive 93/42/EEC, stating the manufacturer's Notified Body. Verifies the compliance of the SIROLaser Blue



This label stands for device compliance of the wireless foot pedal

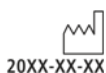

Date of manufacture: yyyy-mm-dd



Best before date – Do not use after: year-month



Batch number



Single-use fiber tip is sterile, sterilized with gas (ethylene oxide)



Single-use fiber tip is not sterile



Steripoint® as evidence of sterilization process
Filled with green dot: EO processed

SN

Serial Number

REF

Reference number



Please refer to manual first (IEC 60601-1 3rd ed.)



Please observe the user manual of the laser unit



Do not use when packaging is damaged



Temperature limitations, transport and storage



Protect against moisture, keep dry



Fragile, Handle with care



Please refer to manual first (IEC 60601-1 3rd ed.)



Power switch (on the backside of the control unit)

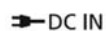

Connection socket for DC input from Sinpro MPU101-106 power supply



Connection socket for interlock



Connection socket for USB



Interference is possible in the vicinity of the device



The disassembled handpiece sleeves may be sterilized only in autoclaves with saturated water vapor at minimum sterilization values of 135°C (275°F), 3 min. holding time and 2.04 bar (29,59 psi) overpressure.



Single-use only for sterile delivered fiber tips, no reuse



Refers to directive 2002/96/EC and EN 50419
Do not dispose with domestic waste



Laser radiation warning

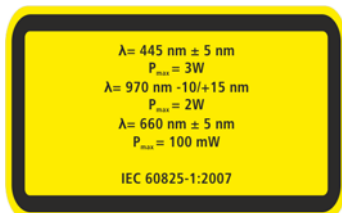

Specification of laser output power and wavelength of blue, IR and red/aiming beam, see also chapter "Technical Data [→ 21]".



Warns of potential laser radiation hazards when opening the laser unit.

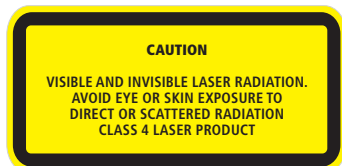

Warns of Class 4 laser radiation hazards when using the unit.

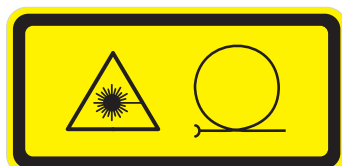

Warns of laser radiation emission at the distal tip of the handpiece.



Warns of laser radiation hazards when the fiber connector is unscrewed.



"Laser Stop" key: press this button in case of an emergency

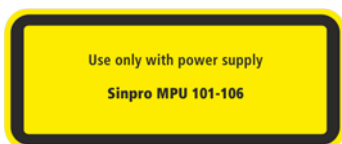

Operate the unit exclusively with the Sinpro MPU101-106 power supply

3.3.2 Abbreviations

NOHD	Nominal ocular hazard distance	VA	Volt-ampere
CW	Continuous Wave	V_{eff}	Effective voltage
PF	Pulsed Frequency or Chopped Mode	V_{th}	Threshold voltage
cont.	continuous	V/m	Volt per meter
approx.	approximately	mA	Milliampere
IR	Infrared diode	A/m	Ampere per meter
g	Gram	mW	Milliwatt
kg	Kilogram	W	Watt
μs	Microseconds	P	Power
ms	Milliseconds	P_{max}	Maximum power
s	Seconds	J	Joule
μm	Micrometer	RF	Radiofrequency
nm	Nanometer	Hz	Hertz
mm	Millimeter	kHz	Kilohertz
cm	Centimeter	MHz	Megahertz
m	Meter	GHz	Gigahertz
WxLxH	Width x length x height	kPa	Kilopascal
DC	Direct current voltage	kpsi	Kilo-pound-force per square inch
AC	Alternating current voltage	db/km	Decibels per kilometer
mV	Millivolt	$^{\circ}\text{C}$	Degree Celsius
V	Volt	$^{\circ}\text{F}$	Degree Fahrenheit
kV	Kilovolt		

3.4 Technical Data

General

Beam guide:	Flexible quartz glass fiber
Display:	Full color, graphical LCD touch screen
Cooling:	Internal air cooling controlled by output
Temperature switch:	Software temperature switch at 48° C
Door contact connection:	Potential-free contact 5 VDC/20 mA (TTL)
Dimensions (W x L x H):	~ 182 x 197 x 189 mm
Weight:	~ 1300 g (incl. handpiece and rechargeable battery)

SIROLaser Blue specification

Laser type:	Diode laser
Wavelengths & optical power:	445 ± 5 nm / approx. 0.2 - 3.0 W (CW) 970 -10/+15 nm / approx. 0.2 - 2.0 W (CW) 660 ± 5 nm / approx. 0.5 - 100 mW (CW)
Laser system:	445 & 970 nm: Class IV 660 nm: Class I (according to IEC 60825-1)
Device classification:	Class IIb (according to Council Directive 93/42/EEC)
Emission modes:	CW (continuous wave), chopped 1 Hz to 10 kHz
Pulse:	Repeated pulse
Pulse duration:	Chopped mode: 10 µs - 0.99 sec.
IP degree of protection:	Laser unit: IP20; wireless foot control: IPX5 (according to EN IEC 60601-1)
Aiming beam:	660 ± 5 nm, max. 1 mW
NOHD:	From the distal end of the optical fiber: 1.5 m
Optical fiber thickness:	200 and 320 µm (single-use fiber tips) 4 and 8 mm (glas rods)
Operation:	Electrical wireless foot control or finger switch, with electronic access key
Nominal power input:	15 V DC 6.66 A max. 100 VA MPU101-106
Insulation class:	Class I, type B (according to IEC 60601-1)
Type of protection against electric shock:	Warning: To avoid the risk of electric shock, this equipment must only be connected to a supply mains with protective earth.



Power supply:	The SIROLaser Blue may only be operated with the Sinpro MPU101-106 power supply. Input voltage: 100 - 240 VAC Input current: 1.25 - 0.5 A Input frequency: 47 - 63 Hz
Separation of mains:	The separation of the mains of SIROLaser Blue is conducted by unplugging the plug of the power supply on the backside of the unit's housing.

Optical fibers specification

Optical fiber diameters:	200 µm fiber	320 µm fiber
Core diameter:	200 µm	320 µm
Cladding diameter:	240 µm	385 µm
Coating diameter:	270 µm	408 µm
All diameters ± 20%		

Optical fiber length:	200 µm fiber: 13 ± 1 mm (end of tube to end of fiber) 200 µm fiber Endo: 27 ± 1 mm (end of tube to end of fiber) 320 µm fiber: 13 ± 1 mm (end of tube to end of fiber)
Tube length:	200 µm fiber: ~ 25 mm 200 µm fiber Endo: ~ 25 mm 320 µm fiber: ~ 25 mm
Minimum transmission efficiency at related wavelength:	The optical fiber material has an attenuation of around 1 dB/km @970 nm
Maximum transmission power:	100 kW/mm ² (Nd:YAG, cw at 1060 nm)
Numerical aperture:	≥ 0.22
Tensile strength:	70 kpsi

Wireless foot control

Frequency:	2.4 GHz - 2.4835 GHz (ISM band)
Transmitting power:	< 2 mW (short-range device)
Modulation type:	Multi-dimensional Multi Access (MDMA)
Battery:	Type AAA, 1.5 V

Transport and storage

The SIROLaser Blue comes in a cardboard box that ensures proper and easy transport.

CAUTION

Do not leave the SIROLaser Blue in a vehicle parked in the sun. The inside temperature of the car could thus heat up to a point where individual components may be damaged.

To ensure appropriate storage, the device must always be kept in the box supplied by Sirona Dental Systems.

Thus stored, the SIROLaser Blue can withstand the following ambient conditions:

- Temperatures from -40° C to +70° C
- Relative humidity from 10 % to 95 %
- Atmospheric pressure from 50 kPa to 106 kPa

NOTICE

The rechargeable battery must be fully charged regularly. After six months of no charging (storage) the rechargeable battery might lose its loading capacity and might not be rechargeable anymore.

In its original transport packaging, the SIROLaser Blue can withstand the following ambient transport conditions:

- Temperatures from -40° C to +70° C
- Relative humidity from 10 % to 95 %
- Atmospheric pressure from 50 kPa to 106 kPa

Operating conditions

The SIROLaser Blue may be operated in the following environmental conditions:

- Temperatures from +10° C to +33° C
- Relative humidity from 10 % to 95 %
- Atmospheric pressure from 80 kPa to 106 kPa

CAUTION

Following transport and storage, let the SIROLaser Blue adapt to room temperature for about one hour prior to operation to reduce the risk of malfunctions caused by condensation.

Sterile delivered single-use fiber tips

Labeling

Each tip is sterilized with gas (ethylene oxide). A label on the outer packing of each set of 25 single-use fiber tips indicates the sterilization procedure (see 3.3.1 symbols).

A green dot on the label of the outer packing serves as a process indicator for a correct sterilization process (see 3.3.1 symbols).

WARNING

Do not use the single-use fiber tips if there is no green dot on the label of the outer packaging.

Storage

To ensure the proper storage and therefore the sterility of the tips, the following environmental factors have to be considered in terms of storage:

- Protection from moisture
- Pollution
- Mechanical stress
- Direct solar or UV radiation
- Influence of temperature
- In a closed storage system (e.g. cupboard, drawer), or
- in shelves or rooms of the room class II according to DIN 1946-4: 2008 -12
- From 15°C to 25°C (room temperature)
- Under relative humidity from 40% to 60% (dry conditions)

Only store the single-use fiber tips in the outer packaging, which serves as the safety packaging (carton).

Use firstly the oldest tips according to their best-before month. It is labeled on each packaging tube of the tips and on the outer packaging of the tip set. The remaining quantity remains in the closed outer packaging (carton).

Do not refill an outer packaging (carton) of the single-use fiber tip sets with new tips.

4 Installation

Any national or local regulations stipulating that the SIROLaser Blue may be installed only by trained personnel must be strictly observed.

4.1 Scope of supply

The following components are included in the scope of supply of the SIROLaser Blue:

	Order-No
SIROLaser Blue	see below
1 x SIROLaser Blue control unit including handpiece with integrated finger switch	
1 x Additional handpiece sleeve for alternating operation	
1 x Demo set of single-use fiber tips (non-sterile demo fibers): 6 x EasyTip 320 µm	
1 x Fiber cutter	
1 x Bending tool	
1 x Rechargeable battery (already mounted)	
2 x Laser protective goggles for operator and assistant	
1 x Laser protective goggle for patients	
1 x Switching power supply	
1 x Transport packaging	
Language-specific documentation set, e.g. User Manual	
Country-specific power cable	see "Spare parts [→ 26] "
Option: Wireless foot control	62 56 841
SIROLaser Blue Order-No for the following countries:	
	Order-No
Germany, Austria	65 40 491
Switzerland	65 40 632
Netherlands, Belgium	65 40 509
France	65 40 640
England	65 40 624
Denmark	65 40 616
Finland, Norway, Sweden	65 40 590
Italy	65 40 657

Spain	65 40 608
Portugal	65 40 665

Further countries on request.

4.2 Spare parts

	Order-No
Handpiece sleeve with keypad	62 56 767
Keypad finger switch	64 87 800
EasyTip 320 µm (25 pieces)	64 98 062
EasyTip 200 µm Endo (25 pieces)	65 35 905
MultiTip 8 mm, therapy light guide	65 41 465
MultiTip 4 mm, therapy light guide	65 41 499
Optic protection cap for handpiece	65 52 108
EasyBend - Bending tool	65 44 097
Fibercutter	60 91 669
Laser protective goggles	65 41 515
Laser protective goggles for spectacle wearers	65 46 407
Laser protective goggles for patients	65 41 523
Battery Pack	62 56 833
Switching power supply	65 59 418
Power cord EU	62 58 581
Power cord IT	62 58 607
Power cord GB	62 58 599
Power cord US	62 58 615
Power cord AUS	62 58 565
Power cord DK	62 58 573
Power cord CH	62 69 554

4.3 Labels

Attach the appropriate language-specific labels (1 and 2) to your laser unit. For more information on the labels and their position, refer to "Appendix B -Label positions [→ 76]".

4.4 Initial start-up – procedure for proper assembly

1. Install power supply
2. Handpiece and assembly of single-use fiber tips and therapy rods
3. Install wireless foot control – optional
4. Install remote interlock – optional
5. Start SIROLaser Blue for the first time

4.4.1 Install power supply

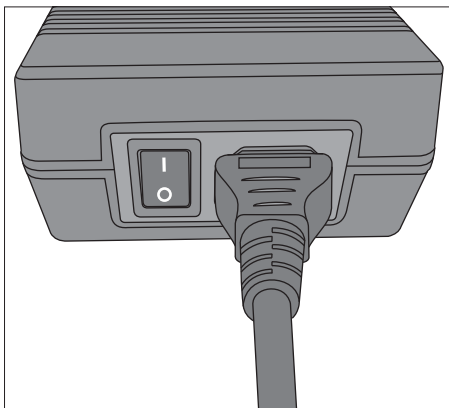

1. Connect the power cable to the DC IN socket at the back of the SIROLaser Blue.
2. Please make sure to switch on the switching power supply.
 - ↳ The green LED on the power supply lights up.

CAUTION

The SIROLaser Blue may only be operated with the Sinpro MPU101-106 power supply. Operation with other power supplies may result in failure or destruction of the laser unit. If any power supply other than the one recommended is used, the approval of the entire unit automatically becomes void and the warranty granted by Sirona Dental Systems GmbH expires.

The use of any power supplies other than the one recommended may cause overheating and failure of the laser unit or damage of batteries.

The SIROLaser Blue is supplied with a rechargeable battery and therefore can be used without connected power cable. The status of the rechargeable battery and whether the power cable is actually connected will be always displayed on the touch screen.

NOTICE

There will be a warning if the rechargeable battery will reach a low level of capacity.

The SIROLaser Blue is fully functional and can be run while charging the battery.

- Charge the battery completely.

NOTICE

The rechargeable battery must be fully charged regularly. After six months of non-charging the rechargeable battery might reduce its loading capacity.

4.4.2 Handpiece and assembly of single-use fiber tips and therapy rods

4.4.2.1 Handpiece

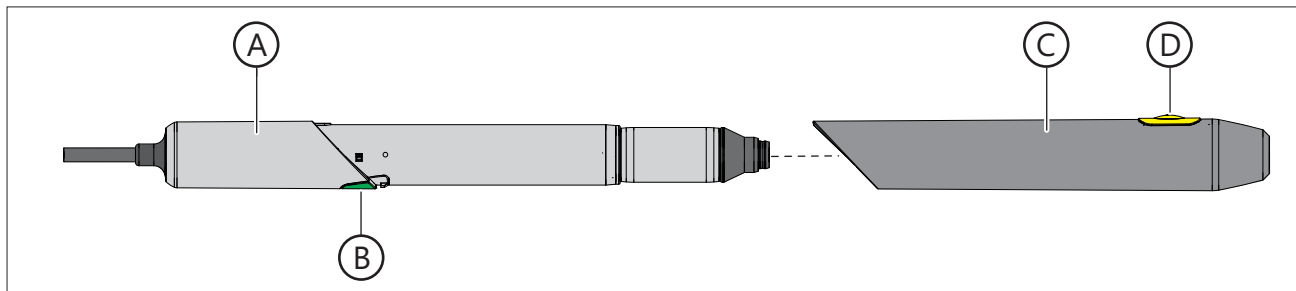

A	Handpiece body with tube
B	Snap tab
C	Stainless steel handpiece sleeve
D	Keypad for finger switch

4.4.2.2 Assembly of sterile single-use optical fiber tips

4.4.2.2.1 Area of application

The SIROLaser Blue is provided with three types of sterile single-use optical fiber tips of different diameter so that it can be used for a variety of different dental procedures and indications:

- Single-use optical fiber tip, EasyTips 320 µm (sterile)
- Single-use optical fiber tip, EasyTip Endo 200 µm (sterile)

EasyTips are delivered sterile in a special packaging tube, which also assists the mounting of the fiber tips. The optical single-use fiber tips can be used only with the SIROLaser Blue in the spectral range of 445 nm ± 5 nm and 970 nm -10/+15 nm.

! WARNING

If optical fiber tips from other manufacturers are used, physical properties such as load carrying capacity and transmission behavior may vary. Sirona Dental Systems GmbH therefore assumes no liability in such cases. Therefore, use only Sirona single-use optical fiber tips.

! WARNING

The fiber tips from the demo set of single-use fiber tips in the scope of supply serve only as test fibers for first familiarisation with the unit. They are not sterile, as shown on their label. Do not use them for clinical treatments at patients.

! WARNING

Do not sterilize the single-use fiber tips (EasyTips) again after usage. Sterilization effects strongly the characteristics of the single-use fiber tips (laser power output, form, accuracy,...).

4.4.2.2.2 Preparation for clinical application

1. The EasyTips are delivered sterile. The metal handpiece sleeve can be cleaned in the autoclave (high-pressure sterilizer), see chapter "Cleaning, disinfection and sterilization [→ 61]".
2. Select the required sterile EasyTip (320 µm or 200 µm Endo), see chapter "List of preset indications [→ 57]".

WARNING

Use of the laser unit when the aiming beam is not functioning properly may cause injuries to operating personnel, assistants or patients. If you cannot see the red aiming beam after switching the laser on or during treatment refer to chapter "Troubleshooting of simple defects [→ 65]".

The optical fiber of the EasyTip may be damaged if it is seriously bent. This may constitute a health hazard for patients, dentists and dental assistants.

Remove the protection cap for treatment only. Never touch the proximal end of the ferrule and protect them against damage and dirt.

Never use the laser without optical fiber, check for correct fixation. Never bend, fold or jam the EasyTips, as this might cause it to break. The EasyTip must never be bent without the bending tool.

Never pull on the optical fiber of the EasyTip.

Mounting of the EasyTip:

Do not use the EasyTip if its packaging tube is damaged or the best-before date has expired. The best-before date is printed on the product label of the packaging tube.

WARNING

If the EasyTip is used after the best-before date, the required sterile conditions of the EasyTip in the packaging tube are only covered until the best-before date. Moreover, some of its physical properties, e.g. its load carrying capacity and transmission behavior, may change, thus posing a hazard to the health of the patient, the dentist and the dental assistant.

After removal of a tip, immediately lose the outer packaging.

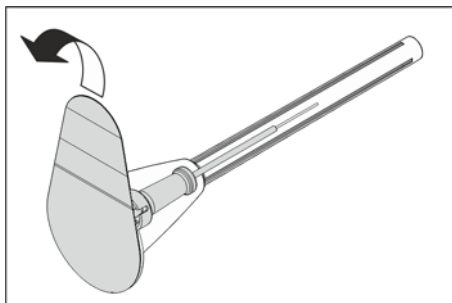
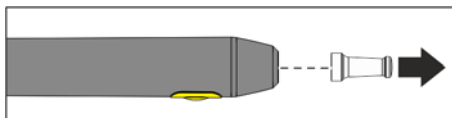

1. Remove the protective cap from the connection socket at the handpiece
2. Open the sterile transport packaging tube of the EasyTip by tearing off the seal label from the top of the packaging.

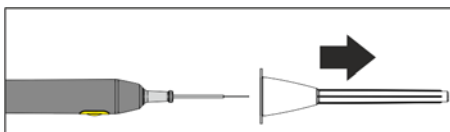
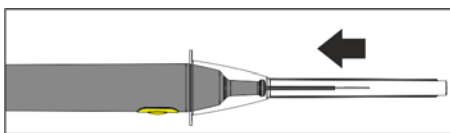

3. Position the packaging tube with the EasyTip on the connection socket by placing the funnel-shaped end of the packaging on the handpiece
4. Press the packaging tube with the EasyTip with light pressure against the handpiece, until the EasyTip perceptibly clicks into place and is firmly seated
5. Subtract the packaging tube from the handpiece and the connected EasyTip
6. Please check whether the EasyTip is firmly seated on the handpiece and perform a visual check to make sure that it has not been damaged during shipment.
7. Put the laser into operation by choosing any preset treatment. A corresponding description is provided in chapter "Operation [→ 36]".

WARNING

The aiming beam must not be aimed toward a person's eye. It comprises an intensive light source even when set to a low power level. Always wear protective goggles.



8. As soon as the SIROLaser Blue is ready you can check to make sure that the aiming beam illuminates evenly, i.e. projects a circular light pattern (see adjacent picture). To do this, aim the EasyTip vertically at a white background. If the beam shows no pattern or the beam pattern is not illuminated evenly, the EasyTip may be damaged or defective. In this case, return the EasyTip to your dental dealer so that it can be replaced under warranty. Do not use any defective EasyTips.

Bending of the EasyTip

1. Please sterilize the bending tool prior to each use to keep the sterile conditions of the EasyTip, see chapter "Cleaning, disinfection and sterilization [→ 61]"
2. Now you can insert the EasyTip into the bending tool and bend the EasyTip to the angle that you need for best handling.

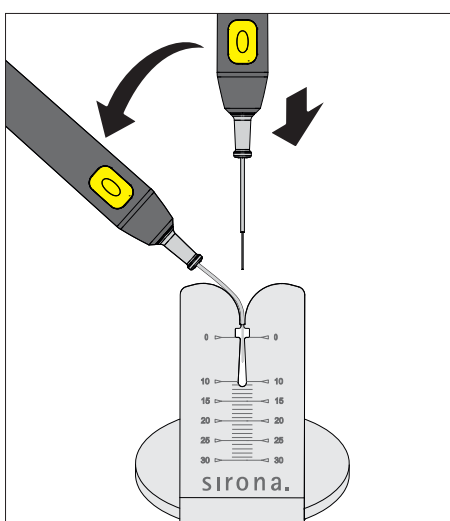

Adjusting the position of the endo stopper

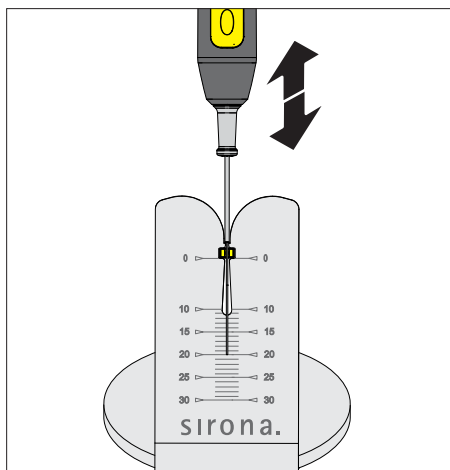

The single-use fiber tip for endodontic applications (EasyTip Endo) is provided with an already mounted endo stopper, which serves as a stop collar for the length of the root canal. The endo stopper can be moved on the optical fiber.

1. To guarantee the sterile conditions of the fiber tip, please use the sterilized bending tool to adjust the position of the endo stopper.
2. Place the EasyTip in the bending tool so that the endo stopper positions itself in the notch for the stopper at the bending tool.
3. Adjust the position of the endo stopper by moving the handpiece up and down so that the end of the fiber tip has the needed distance to the stopper (indicated by the mm scale on the bending tool).

Adjusting the fiber length with the fiber cutter

Generally, all types of sterile delivered single-use fiber tips have the proper fiber length in order to start working immediately without the need of adjusting the length prior to application. However, in some cases it will be necessary to adjust the length of the fiber.

Please sterilize the fiber cutter prior to each use to keep the sterile conditions of the EasyTip, see chapter "Cleaning, disinfection and sterilization [→ 61]".

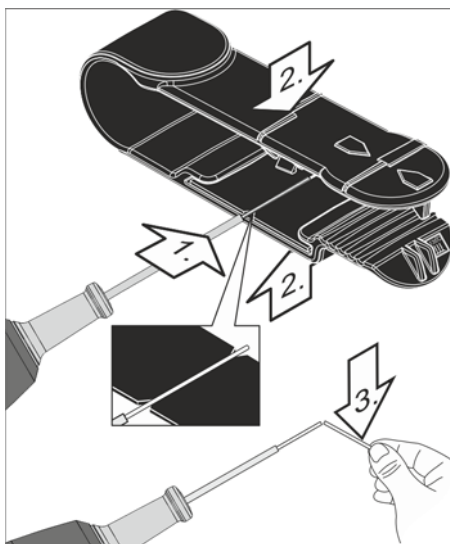

1. Place the optical fiber of the EasyTip in the fiber cutter at the notched mark.
2. Press the fiber cutter together and release it again.
3. Bend the optical fiber at the notched location.
 - ↳ The optical fiber breaks at the notched location with a smooth, perpendicular fracture surface.

Check to see if the light of the aiming beam projects a uniform circular pattern. To do this, aim the optical fiber vertically at a white background. If the probe projects no pattern at all or only an uneven pattern, cut off another one to two millimeters.

NOTICE

Press firmly but do not squeeze the optical fiber. You just need a little notch to receive a perfect result when breaking the fiber at the notch.

⚠ WARNING

If the optical fiber of the EasyTip does not protrude at least 5 mm out of its metal tube, there is a risk that the tube will heat up.

After treatment

The easiest and safest way to dismount the EasyTip from the handpiece after treatment is to use a disposable container.

1. Open the lid of the disposable container and connect the plastic grip of the tip to the suitable recess inside the container.
2. Remove the EasyTip from the handpiece by pulling the container away from the handpiece.
3. The EasyTip falls into the disposable container.
4. Close the disposal container.

CAUTION

As soon as you disassemble the EasyTip after treatment make sure to protect the optical fiber socket with the protective cap provided for this purpose. Make sure that no dust or dirt can enter the optical system. Otherwise the unit may be permanently damaged.

4.4.2.3 Assembly of therapy light guides

4.4.2.3.1 Area of application

The SIROLaser Blue can be used for additional dental procedures with two types of reusable therapy light guides of different diameters:

- Light guide (MultiTip 8 mm), diameter: 8 mm
- Light guide (MultiTip 4 mm), diameter: 4 mm

The light guides are delivered non-sterile.

WARNING

After 2,000 sterilization cycles or 2 years which marks the end of the service period, the MultiTips will have reached their wear limit. Please check the usage period based on the LOT number (definition of LOT = week year e.g. 0215 for calendar week 2, 2015). Please replace the light guide accordingly. The optical output can be reduced.

The MultiTips can be used only with the SIROLaser Blue in the spectral range of 445 nm \pm 5 nm, 660 nm \pm 5 nm and 970 nm -10/+15 nm.

If light guide rods from other manufacturers are used, physical properties such as load carrying capacity and transmission behavior may vary. Sirona Dental Systems GmbH therefore assumes no liability in such cases. Therefore, use only Sirona light guide rods.

4.4.2.3.2 Preparation for clinical application

WARNING

For safety reason it is necessary to use the 4 mm or the 8 mm light guide (MultiTip) if wavelength of 660 nm is chosen

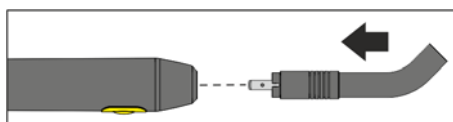

1. The MultiTips are delivered non-sterile. Make sure that the rod is clean and sterile. The metal handpiece sleeve can be cleaned in the autoclave (high-pressure sterilizer), see chapter "Cleaning, disinfection and sterilization [→ 61]".
2. Select the required MultiTip light guide (diameter 8 mm or 4 mm), see chapter „List of preset indications”.
3. Please perform a visual check to make sure that the MultiTip is not damaged or has not reached its wear limit.
4. Put the optical connection of the MultiTip on the optical socket of the handpiece. Press the MultiTip with light pressure against the handpiece, until the MultiTip perceptibly clicks into place and is firmly seated.
5. Put the laser into operation by choosing any preset treatment destined for the light guide. A corresponding description is provided in chapter "Operation [→ 36]".

WARNING

Use of the laser unit when the aiming beam is not functioning properly may cause injuries to operating personnel, assistants or patients. If you cannot see the red aiming beam after switching the laser on or during treatment refer to chapter "Troubleshooting of simple defects [→ 65]".

Only use the MultiTips for treatments destined for them. EasyTips and MultiTips have completely different optical characteristics.

Remove the protection cap of the handpiece optic for treatment only.

Never touch the proximal end of the ferrule and protect them against damage and dirt.

Never use the laser without optical fiber, check for correct fixation.

After treatment

Dismount the MultiTip from the handpiece by deducting it carefully from the optical socket of the handpiece.

CAUTION

As soon as you disassemble the MultiTip after treatment make sure to protect the optical fiber socket with the protective cap provided for this purpose. Make sure that no dust or dirt can enter the optical system. Otherwise the unit may be permanently damaged.

For cleaning, disinfecting and sterilizing the MultiTip please refer to chapter "Cleaning, disinfection and sterilization [→ 61]" [→ xx].

4.4.3 Install wireless foot control – optional

The SIROLaser Blue can be operated using the finger switch (which is integrated in the handpiece) as well as by using the optional wireless foot control.

NOTICE

The foot switch has an IPX5 degree of protection. Therefore this foot switch must not be used in hospital operating rooms.

Technical data of the wireless foot control, see chapter Technical Data, "Wireless foot control".

The wireless foot control must be assigned to the SIROLaser Blue via a registration. This prevents malfunctions caused by neighboring wireless controls.

- ✓ The SIROLaser Blue control unit and the wireless foot control are ready for operation.
- 1. Choose in main home screen the item "Settings".
- 2. Choose there the item "Activation device".
- 3. Choose the "Wireless registration".
- 4. Follow the instructions on the screen and press first the foot switch for three seconds.
- 5. After this press the registration key on the top of the wireless foot control radio box for three seconds.
 - ↳ After this the device shows a mac address of the pedal and ask to confirm the pairing within 20 sec.
 - ↳ Confirmation via 'OK'.
- 6. To use the wireless foot control, choose in submenu "Settings" in "Activation device" the wireless foot control.



NOTICE

The finger switch is pre-set.

4.4.4 Install remote interlock – optional

Explanation

The interlock is a safety device that stops laser radiation whenever the door of the treatment room is opened. The interlock circuit must be connected to a switch that is located near the door of the treatment room in order to ensure automatic interruption of the laser emission.

NOTICE

The installation must be performed by a qualified electrician who is also responsible for the installation and maintenance of the electrical system to which the SIROLaser Blue is connected.

NOTICE

Additional or different safety precautions required by the applicable national or local regulations for the protection of dentists, assistant personnel, or patients must also be observed.

Installation of an interlock with door switch

1. Prepare the interlock plug by connecting the interlock cable with the interlock plug and by opening the bridge. Please find the technical data sheet with circuit diagram for the installation of the interlock circuit in "Appendix C – Safety circuit (interlock) [→ 78]".
2. Mount the prepared interlock plug into the interlock socket on the backside of the SIROLaser Blue.

5 Operation

5.1 Start the device for the first time

NOTICE

Touch screen functionality: When the touch screen is touched by the finger the touch field is highlighted. As soon as the finger leaves the touch screen the action will be started.



Battery state

Information concerning the remaining battery power



Connected/charging battery

Battery is connected to power supply and charging



Activate Laser

Laser is being activated



Back

User goes back one screen



Home

User goes directly back to home screen



OK

User agrees to settings, confirms and activates action



Save

Settings of application will be saved in My Applications



Delete

Settings of application will be deleted from My Applications. Defined users will be deleted from the user list.



Continuous wave

Laser is being set for continuous wave mode



C (clear button)

User clears letters or digits (going backwards)



Help

User wants to open additional help information to this application



'Plus' and 'Minus'

User is able to count up and down respectively can move cursor to the right or left side



'Forward' and 'Backward'

User is able to scroll forward and backwards (if there is more than one page of this screen)



User Change

Change the user by entering the password dialog



Settings

User is able to do all the necessary settings, e.g. language settings



All applications

User is able to select an application from all applications or to define an own application

NOTICE

Alphabetic and numeric letters, limitation to data input:

- Numbers are displayed with English decimals '.' for all languages/ regions.
- The power for 445 nm and 970 nm is displayed with one decimal place. Unit is watt (W).
- The power for 660 nm is displayed with no decimal place. Unit is milliwatt (mW).
- The time can be set-up as continuous or 1 to 9999 seconds. If continuous is selected it counts up to maximum 9999 seconds after activating application. If time is fixed it counts down. Unit is seconds (s). If 9999 is exceeded treatment will stop and display jumps back to treatment screen.
- The duty cycle is displayed in 1% steps, from 1% to 100% without unit. 100% is displayed as CW.
- The frequency can be entered by typing in the numbers or by moving higher or lower by using 'plus' or 'minus'. If using 'plus' or 'minus' the frequency will be set from 1 Hz -10 Hz in increments of 1 Hz, from 10 Hz -100 Hz in increments of 10 Hz, from 100 Hz -1 kHz in increments of 100 Hz and from 1 kHz -10 kHz in increments of 1 kHz. If 0 Hz is set, CW is displayed. Unit is hertz (Hz).
- Between 1 kHz -10 kHz the duty cycle cannot be below 10% and above 90% due to physical limits. So, at 1 kHz -10 kHz any input below 10% will automatically be displayed and used as 10% for the treatment as well as any input above 90% will automatically turn into 90%.
- The average power will automatically be calculated and displayed with one decimal place for 445 nm and 970 nm, with no decimal place for 660 nm. Unit is watt (W) for 445 nm and 970 nm, milliwatt (mW) for 660 nm.

Clear screen before entering new parameters or data. Existing entries will not be overwritten.

Newly generated applications or changed parameters of preset applications will appear in red.

5.2 Switch on/off power

Switch on the laser device

After starting the SIROLaser Blue by switching on the on/off button on the backside of the control unit the LEDs will blink.

While the SIROLaser Blue is booting information about the software version and the set language as well as the advice to read the user manual will be displayed.

IMPORTANT

In some cases when the laser has been switched off for a longer time, it may be necessary to press the on/off button two times to start the unit.

When starting the SIROLaser Blue for the very first time you will automatically be asked to set-up the unit. Please proceed as requested:

1. Language
Choose your language and press 'OK'. See also chapter "Language [→ 52]".
2. Date & time
Please enter the appropriate date & time and press 'OK'. See also chapter "Date & time [→ 47]".

Switch off the laser device

To switch off the laser device press the on/off button on the backside of the control unit. The unit will ask you then to confirm switching off by pressing the "OK" button on the screen.

NOTICE

After switching off the laser device, it is not possible to immediately restart the unit due to the shutdown off the unit. Please wait a few seconds until the shutdown is completed.

WARNING

The laser main switch does not disconnect the battery loading circuit, i.e. the batteries are loaded even if the laser is switched off.

In any unpredicted case, the laser device can be also switched off by pressing the on/off button on the backside of the control unit longer than 5 seconds.

Laser stop

In case of emergency press the laser stop button. Note, that the laser is interrupted and deactivated, but not switched off. If you want to continue, enter the pin code

5.3 Enter pin code

The SIROLaser Blue may be operated only by authorized personnel and has an electronic key for security purposes.

- Enter the key user pin code **2 9 7 4**.
- ↪ The unit automatically jumps into the home screen, if the correct pin code has been entered.

WARNING

Do not give the access code to unauthorized third parties. Risk of misuse of the laser by unauthorized persons!

This pin code is changeable in the settings menu.

NOTICE

In case the key user forgets his/her pin code please enter the super pin code **2 8 7 7**. The super pin code is never changeable.

5.4 Sleep Mode

After 10 minutes, the unit falls into the sleep mode. During the sleep mode, the LEDs are blinking blue. After touching the display, the unit will immediately wake up and jumps into the password screen.

5.5 Main home screen



The following section describes the main home screen. The main home screen includes the following options and information:

- **Favorites**
Use, define or change six favorite applications directly on the home screen.
- **All applications**
After opening the submenu, you will be able to select among different indications with preset treatment parameters out of the areas: Surgery, Periodontology, Endodontics, Soft Laser Therapy, Miscellaneous, and My Applications. All submenus are structured the same way.
- **Settings**
Within this submenu you will be able to configure the SIROLaser Blue to your needs as well as you will find all necessary settings and service programs.
- **User Change**
By pressing the 'user change button' you will jump back to the screen 'enter pin code'.
- **Self Test**
After booting the SIROLaser Blue will automatically perform a self test. The information will be shown in the main home screen.

5.5.1 Self Test

After booting the SIROLaser Blue will automatically perform a self test including a status check of the following matters:

- Wireless foot control vs. finger switch
- USB port

In addition, you will be informed when the next calibration check or when the next servicing is due.

The statuses are displayed on the home screen.

Foot control

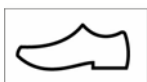

If the wireless foot control is selected in the settings the self test may result in:

The wireless foot control is selected and the appropriate symbol for foot control will be displayed on the home screen confirming selected.

If the wireless foot control is not selected the appropriate symbol for foot control will not be displayed on the home screen.

NOTICE

If the wireless foot control is selected but not detected, please perform the registry of the wireless foot control and/or check the battery, see chapter "Install wireless foot control – optional [→ 34]".

If the wireless foot control remains not selectable please contact your local dental dealer or an authorized Customer Service Department for technical support.

Finger switch



If the finger switch is selected in settings the self test may result into:

The finger switch is connected and the appropriate symbol for finger switch will be displayed on the home screen confirming checked and selected.

If the finger switch is not selected the appropriate symbol for finger switch will not be displayed on the home screen.

NOTICE

If the finger switch is defective/missing the unit shows an error message after booting. In this case please check the cable connection to the SIROLaser Blue control unit, see chapter "Troubleshooting of simple defects". If the finger switch remains defective/missing, please contact your local dental dealer or an authorized Customer Service Department for technical support.

In general: If any switch is defective laser will be blocked.



USB port

To make sure that the USB port is available it is checked within the self test.

If the appropriate symbol for USB port error is not displayed on the home screen, the USB port works properly.

If the symbol is displayed on the home screen, the USB port is defective.

NOTICE

If the USB port error is displayed on the home screen for defective please contact your local dental dealer or an authorized Customer Service Department for technical support.

The SIROLaser Blue will remain functional but the download of the history file / software updates are not possible.

Calibration check

Sirona Dental Systems recommends a calibration check with external powermeter to be performed every twelve months, see chapter "Calibration check using an external power meter [→ 51]".

The information for 'next calibration check' is only displayed on the home screen for the first time after restart or log-in (in month).

For the last 30 days it is displayed continuously on the home screen. After excess of the service interval the days are displayed with a minus [-] and red coloured.

The laser remains fully functional.

Time to service

The safety test is a mandatory test for all medical devices. The SIROLaser Blue needs to be tested once every two years.

The information for 'time to service' is only displayed on the home screen for the first time after restart or log-in (in month).

For the last 30 days it is displayed continuously on the home screen. After excess of the service interval the days are displayed with a minus [-] and red coloured. The laser remains fully functional.

NOTICE

Legal regulations require a regular safety test of the performance of a laser device. The SIROLaser Blue needs to be tested once every two years. Please contact your local dental dealer or an authorized Customer Service Department for technical support.

If internal or external calibration check failed after last calibration a warning screen pops up after self test. The laser remains fully functional.

NOTICE

Please contact your local dental dealer or an authorized Customer Service Department for technical support.

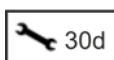
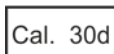

5.5.2 Favorites

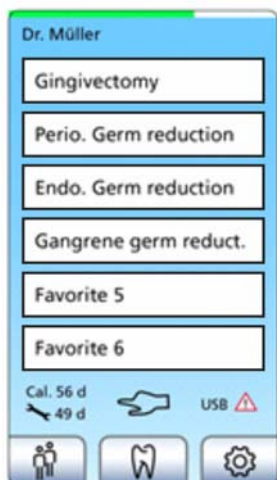

Six applications from pre-set applications within the preset submenus Surgery, Periodontology, Endodontics, Miscellaneous and Soft Laser Therapy or self-defined applications from My Applications can be defined as favorite applications directly accessible from the home screen. Four favorites are already pre-selected at delivery but can be changed.

- To assign an application as favorite to a not yet assigned favorite button, please press the particular favorite button until the screen automatically jumps into the screen "All Applications".
- If a favorite button is already assigned to an application, please press the favorite button until the screen automatically jumps into the screen "All Applications".
- ↪ You will be now able to select one application from the different submenus as the new favorite: Surgery, Periodontology, Endodontics, Miscellaneous, Soft Laser Therapy and My Applications.

5.5.3 Submenu: All applications



The submenus of the surgery, periodontology, endodontics, soft laser therapy and miscellaneous areas as well as the area of own applications are arranged in the same way. After opening the submenus, you can select among different indications with preset treatment parameters.

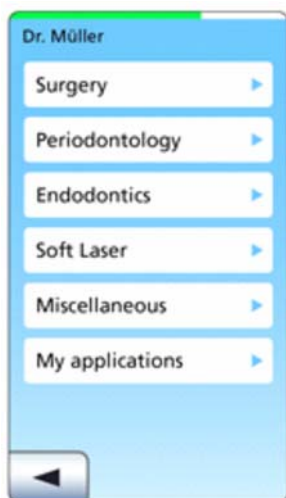

Surgery

- Abscess
- Epulis
- Fibroma
- Frenectomy
- Gingivectomy
- Gingivoplastic
- Implant Uncovery
- Incisions/Excisions
- Operculectomy
- Gingival Troughing

Periodontology

- Periimplantitis (Germ Reduction)
- Perio. Germ Reduction

Endodontics

- Endo. Germ Reduction
- Pulpotomy
- Gangrene Germ Reduction

Soft Laser Therapy

- Burning mouth-syndrome
- Dentin hypersensitivity
- Wound healing

Miscellaneous

- Haemostasis
- Aphthous Ulcers
- Desensitization
- Herpes

My applications

- for 24 own applications

Putting the laser in ready mode

1. Select the desired indication.
 - ↳ The pre-set parameters will be displayed.

WARNING

Check the set parameters before activating the treatment.

2. Now you can activate the laser: Press the 'Activate Laser' button.
 - ↳ You will be advised to wear the correct protective goggles before the aiming beam is activated.
3. Acknowledging the advice.
 - ↳ The green LEDs start flashing. After a delay of 2 seconds, the aiming beam is switched on.
 - ↳ The laser is now ready for operation.

NOTICE

Please do not press the finger switch or foot switch during the 2 seconds of laser activation before being in ready mode to avoid an error message.

WARNING

All persons present in the room (operator, assistants and patient) must wear the proper laser protective goggles as soon as it is advised to wear laser protective goggles and whenever the green LEDs are lit.

Any actuation of the finger or wireless foot control activates the laser unit.

Wrong settings may result in severe damage of the patient's soft or hard tissue or may result in no treatment efficacy. So any user is supposed to have sufficient knowledge and training in laser therapy.

The treatment room must be protected by suitable measures (in compliance with IEC 60825-1), e.g. by closing the doors.



NOTICE

Before starting a laser treatment in battery operation please reconfirm the battery status.

When you activate the finger or wireless foot control, the laser begins emitting. At the same time, two yellow LEDs at the upper right and left end of the SIROLaser Blue control unit light up as well as the laser active bar on the touch screen and the audible alarm sounds. When you release the finger or wireless foot control to interrupt treatment, the laser is deactivated, but remains ready for operation.

The following is a typical example of a treatment submenu.

1. Selected program

in this example Frenectomy



2. Laser power

in our example, 2.0 W power. By pushing on the power touch field you will be transferred to another screen where you will be able to adjust the emitted power between 0.2 W and 3.0 W in 0.1 W increments either by typing in the numbers or by moving higher or lower by using 'plus' or 'minus'.

WARNING

The preset power levels are considered to be safe for patients. Increasing the power levels entails the risk of overheating the patient's soft or hard tissue. Setting the power to excessively low levels may result in reduced treatment efficacy.

3. Time

in our example, continuous. The laser will be activated as long as the finger or wireless foot control is pressed. By pushing on the time touch field you will be transferred to another screen where you will be able to adjust the time between continuous or 1 to 9999 seconds either by typing in the numbers or by moving higher or lower by using 'plus' or 'minus'.

4. Duty cycle

in our example, CW (continuous wave mode). The duty cycle is defined as the ratio between the pulse duration (when the laser beam is actually activated) and the total period of time (which is the time from the beginning of a pulse to the beginning of the next pulse). By pushing on the duty cycle touch field you will be transferred to another screen where you will be able to adjust the duty cycle between 10% and 90% by typing in the numbers or by moving higher or lower by using 'plus' or 'minus'.

NOTICE

If the frequency is set CW the duty cycle will not be changeable.

5. Frequency

in our example, CW (continuous wave mode). This is the modulation frequency of the laser unit. By pushing frequency touch screen you will be transferred to another screen where you will be able to enter the laser operation mode. For more informations about the operation modes, see chapter "Laser operation modes [→ 17]".

Continuous wave

When pushing the 'CW' button the continuous wave mode is set and in the control field appears "CW". Via 'OK' you will be proceeded back to the treatment submenu in which you can further adjust the power and time.

6. Average power

in our example, 2 W (watt). The system calculates the average power (in W) from the power values and the selected duty cycle.

Further more the example here shows:

7. Home button

By pushing the home button you will jump directly to the home screen.



8. Back button

By pushing the back button you will jump back one screen.



9. Help button

By pushing the 'help' button the help menu will be opened and you can read additional information about this treatment.



10. Laser button

By pushing the 'Activate Laser' button the laser will be made ready for operation.



5.5.3.1 My Applications

Up to 24 applications can be generated and saved to My Applications.

NOTICE

If My Applications are full and you try to add another application a warning screen will signal to remove another application from My Applications else the chosen application cannot be saved to My Applications.

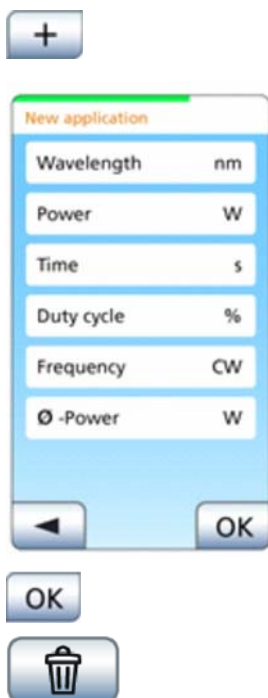

1. If you press on the My Applications screen the 'plus' button a blank input mask is opened.
2. Name the new application by touching the field 'name'.
 - ↳ A keyboard field is shown.
3. Confirm your text input with 'OK'.
 - ↳ The keyboard field is hidden.
4. Enter your desired parameters.
5. The new input will be confirmed by pressing the 'OK' button.

Selected application can be deleted from My Applications by pressing the 'delete' button.

! WARNING

Wrong settings may result in severe damage of the patient's soft or hard tissue or may result in no treatment efficacy. So any user is supposed to have sufficient knowledge and training of laser therapy.

5.5.3.2 Settings



After pressing the ,settings' button on the home screen, the screen jumps into the settings menu

5.5.3.2.1 Activation device



In case you have purchased your SIROLaser Blue with the optional wireless foot control you have the choice to use either the finger switch or the wireless foot control. Select one and confirm by pressing 'OK'.

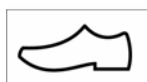

NOTICE

The finger switch is pre-set.

To be able to use the wireless foot control please see chapter "Install wireless foot control – optional [→ 34]" for further instructions.

It is also possible to check the functionality of the finger switch and the foot control (only if it is registered) in this menu:

- Press the finger switch or the foot control.
- ↳ If the pressed activation device works properly, the unit indicates it by beeping of the warning sound. No laser beam is activated during this functionality check.

5.5.3.2.2 Date & time



Format for date: dd/mm/yyyy

Format for time (24hours notation): hh/mm

- Enter date & time and save by pressing 'OK'.

5.5.3.2.3 Sound volume and display settings

Sound volume



1. Select volume level of warning sound and push button sound by using 'plus' or 'minus'.
 - ↳ Level of warning and push button sound will immediately be applied.
2. Save with 'OK'.

Display settings

1. Select level of display brightness by using 'plus' or 'minus'.
 - ↳ Level of display brightness will immediately be applied.
2. Save with 'OK'.

5.5.3.2.4 User management



When entering the user parameters menu, the key user is already configured, similar to a computer administrator. This administrator has the possibility to enter five additional users (via 'plus' button).

NOTICE

The set-up of the key user is fixed and not changeable, but it is possible to give him a user name (e.g. SMITH instead key user) and to change the pin code 2 9 7 4.

The key user is the administrator of the SIROLaser Blue and has all rights to create and configurate five new users as well as to remove them from the list of users.

The additional users will have access only to limited parts of the settings: Language, display setting, sound volume, history file, finger or foot switch, battery calibration.

The configuration for the selection finger or foot switch, and the screen and volume settings are not stored individually.



If key user presses the 'new' button on user parameters screen a blank file is opened.

- To enter the name, pin code and other settings of the new user press the appropriate buttons.

The key user decides if this user will be allowed to change preset applications.

NOTICE

If 'no' is entered there will be no My Applications screen for this user.

The key user decides if this user will have a power limit for treatments. If yes is entered the key user also enters the power limit in watt.

NOTICE

The power limit directly influences the number of applications that can be used by this user.

For example, when you choose a power limit of 2 W the user can not choose preset indication with more than 2 W. If the power limit 0.5 W (default) so the user has no access to preset indications.

The key user is able to select the applications this user is allowed to use.

NOTICE

The non-usable applications due to the direct selection or the power limit appear shaded and are disabled.

5.5.3.2.5 Software update

If a software update of the SIROLaser Blue is needed please proceed as follows:

CAUTION

Use a USB class 2.0 (or above) memory stick.
To perform the software download use a USB stick with a minimum capacity of 512 MB.
Specify the USB configuration that is FAT32 and NTFS.

1. Choose in main menu the item "Settings".
2. Choose there the item "Software update".
3. Follow the instructions in the note message and insert the USB stick.

NOTICE

Please bear in mind that the system requires approx. 5 seconds to detect the USB stick.

- ☞ The message "updating software..." and an hour glass appears which indicates that the software update is in progress.
- ☞ After this, the unit automatically reboots with the 2 LEDs lighting orange and a white screen.

CAUTION

Leave the USB stick and the power cable plugged in until the completion of software update.

The Software update may take up to five minutes.

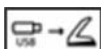

4. Enter the pin code.

- ↳ The software update was successfully performed. The USB stick can be removed.

5.5.3.2.6 History file



After having finished a treatment all parameters will be saved and documented in the history file - i.e. user name, application, date & time as well as power, laser activation time, energy, and average power of this treatment.

NOTICE

A maximum of 50 treatments is possible to be stored. If the maximum is reached the 51st treatment will replace the 1st treatment.

When downloading the history file the data of this user will be deleted from the control unit.

CAUTION

Use only USB Class 2.0 memory sticks.

To perform the download of the history files use a USB stick with a minimum capacity of 512 MB.



- To download the history file please insert an USB mass storage and press the 'save' button.

- ↳ Proceed as instructed on the screen.

5.5.3.2.7 Battery calibration

For perfect battery performance a battery calibration must be proceeded in any case of having removed and again mounted or completely replaced the battery pack, see chapter "Replacing the rechargeable battery of the control unit [→ 67]".



1. Switch on the laser without having connected the power supply.
2. Choose "Battery calibration" in the settings menu.
 - ↳ The following message will appear. "Battery calibration may take several hours."
3. Press 'OK'.
 - ↳ The battery will now be discharged automatically until the device switches off due to lack of power.
4. When the device has been switched off automatically plug in the power supply and charge the battery for at least 2 hours (best over night).
 - ↳ Now the battery is calibrated.

5.5.3.2.8 Laser calibration check



! WARNING
You must wear the supplied laser protective goggles during the entire calibration check.

The following section describes the procedure to check the calibration of the SIROLaser Blue.

We recommend performing this check at least once a week.

In order to enable exact inspection of the performance and flawless functioning of your SIROLaser Blue, we recommend performing calibration check at the following different stages:

- 1 W (445 nm)
- 1 W (970 nm)
- 100 mW (660 nm)

The SIROLaser Blue performs a self-calibration. During this procedure, the system checks that the laser emission parameters are correct. We recommend that you check these values using a suitable external measuring instrument at least every twelve months. If the measurement readings indicate the following values, the calibration is correct:

- wavelength: 445 ±5 nm
power: 1 W
resolution: 5 % or higher
- wavelength: 970 -10/+15 nm
power: 1 W
resolution: 5 % or higher
- wavelength: 660 ±5 nm
power: 100 mW
resolution: 5 % or higher

Select one of two test procedures to check the calibration:

5.5.3.2.8.1 Calibration check without an external power meter

➤ Select w/o power meter.

Please read the operating instructions and wear protection goggles before proceeding the calibration check.

Now the calibration check starts! Direct the correctly mounted handpiece with correctly installed fiber to a beam dump, i.e. a non flammable object which does not reflect the laser beam.

! WARNING
The calibration check takes place with laser power. Danger for skin and eyes!
Do not direct the laser beam to flammable objects or use the laser with flammable substances or gases around.
Do not direct the laser to reflective (metallic) surfaces. Danger for skin and eyes!

The menu asks you to press the finger switch for 3 seconds.

1. Press the finger switch for at least 3 seconds, the laser will stop emission automatically.
2. Press 'OK'.
3. Repeat the procedure for all wavelengths.

For each value the device compares the delivered current with the calibration value. If the value is inside the tolerance, the test is passed. If the tolerance is out of the tolerance, the test is stopped.

If the calibration check is passed successfully, the message "Calibration Test passed" will appear.

➤ Acknowledge with 'OK'.

If the laser shows an error message, please contact your local service.

5.5.3.2.8.2 Calibration check using an external power meter

Required power meter: Calibrated power meter capable of measuring a power level of at least 1 watt at a wavelength of 445 nm and 970 nm and 100 mW at a wavelength of 660 nm with an accuracy of better than 10%.

➤ Select with external power meter.

Please read the operating instructions and wear protection goggles before proceeding the calibration check.

Now the calibration check starts! Direct the correctly mounted handpiece with correctly installed fiber to the head of your power meter.

WARNING

The calibration check takes place with laser power. Danger for skin and eyes!

Do not direct the laser beam to flammable objects or use the laser with flammable substances or gases around.

Do not direct the laser to reflective (metallic) surfaces. Danger for skin and eyes!

The menu asks you to press the finger switch for 3 seconds.

1. For each value the device asks to perform a measure and indicate if the visualized value is inside the tolerance (value -20% / value +20%).
2. Press the finger switch for at least 3 seconds, while directing the laser to the head of the power meter.
3. Readout the measured power from the display of your power meter.
4. The unit will ask you whether the measured value is inside the tolerance of $\pm 20\%$. Press 'Yes' on the screen if the measured value is inside the tolerance of $\pm 20\%$ Press 'No' if it is outside the tolerance.
5. Repeat the procedure for all wavelengths.

If the calibration check is passed successfully, the message "Calibration Test passed" will appear.

- Acknowledge with 'OK'.

If the laser shows an error message, please contact your local service.

5.5.3.2.9 Language



- You have the choice of different languages. The currently set language is greyed out. Select one and confirm by pressing 'OK'.
 - ↳ Language will be applied after confirmation.

NOTICE

The language will be changed for all users.

5.5.3.2.10 Service Menu



NOTICE

Only authorized persons are allowed to enter the service menu. To avoid misuse it is necessary to enter the eight-digit pin code.

5.5.4 Error messages, warnings and instructions

5.5.4.1 Error messages and warnings



Pin not correct
Confirmation via 'OK' to insert the pin code again.



The screen is displayed in case of anomaly. It avoids hazardous situation resulting from failure of the it-network: downgrade not allowed or corrupted package.
Confirmation via 'OK'.

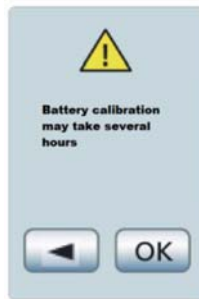

Before battery calibration this screen is displayed.
'OK' for confirmation, 'arrow' to go back to the current screen. No action occurs.



A message warns the user about the missing USB. Please plug a suitable USB device (Version 2.0) into the slot.
Confirmation via 'OK'.



Visualization of "Laser not calibrated" if the calibration test was not successful.
Confirmation via 'OK'.



Displayed in case when temperature sensor of the laser module is defective. Please contact Sirona Dental Systems GmbH, your local dental dealer or your authorized service center.
Confirmation via 'OK'.



Displayed in case when the laser stop button has been pressed.
Confirmation via 'OK'.



Displayed in case of an error of the foot switch. Please contact Sirona Dental Systems GmbH, your local dental dealer or your authorized service center.
Confirmation via 'OK'.



Displayed in case of an error of the finger switch. Please contact Sirona Dental Systems GmbH, your local dental dealer or your authorized service center. Confirmation via 'OK'.



Displayed in case when an error of the fan occurs (for example: the fan is blocked). To avoid damage please switch of the SIROLaser Blue and let it cool down for a while. See chapter "Troubleshooting of simple defects [→ 65]". Confirmation via 'OK'.



Displayed in case when the interlock contact is open. See chapter "Troubleshooting of simple defects [→ 65]".



Displayed in case when the currents of the diode differ more than the 20 percent tolerance compared to the calibrated currents. Please contact Sirona Dental Systems GmbH, your local dental dealer or your authorized service center. Confirmation via 'OK'.



Displayed in case when there is no fiber connection. See chapter "Troubleshooting of simple defects [→ 65]". Confirmation via 'OK'.



The battery level is low and needs to be connected to the power supply. Confirmation via 'OK'.



Device error occurred. Please contact Sirona Dental Systems GmbH, your local dental dealer or your authorized service center. Confirmation via 'OK'.



An error occurred during calibration check (with or without power meter) which could not be handled. Please contact Sirona Dental Systems GmbH, your local dental dealer or your authorized service center. Confirmation via 'OK'.

5.5.4.2 Instructions



The screen describes how to perform the pairing process of the wireless foot switch.



The device asks to remove the power supply before starting battery calibration. Confirmation via 'OK'



The device asks to insert the USB device for downloading the history file (USB 2.0, min. 512MB storage capacity). 'OK' for confirmation, 'arrow' to go back to the current screen. No action occurs.



The device asks to use the protective goggles. 'OK' for confirmation, 'arrow' to come back to the current screen. No action occurs.



Displayed in case of overheating of the laser block. It is requested to wait for cooling. Confirmation via 'OK'



Release the used activation device: footswitch or finger switch
 Displayed when footswitch or finger switch is pressed before the laser is in 'ready mode' (complete green bar). Confirmation via 'OK'.



The MultiTip must be used. Confirmation via 'OK' to insert the pin code again.

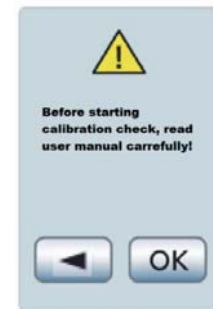

To perform any calibration check it is advised to read the user manual carefully. Confirmation via 'OK', 'arrow' to go back to the current screen. No action occurs.



The unit asks to press finger switch for three seconds. This screen is displayed during laser calibration for the calibration process (without power meter) Confirmation via 'OK'

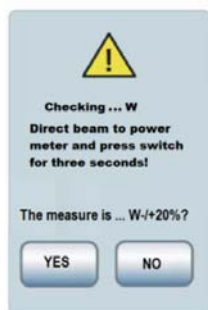

The unit asks to direct the laser beam to the power meter and to press the finger switch for three seconds. This screen is displayed during laser calibration for the calibration process (with power meter). The operator presses 'Yes' or 'No' if the measured value is inside the stated value or not.

5.5.4.3 Information messages

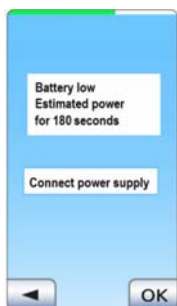

The screen occurs when the battery level is low and the external power supply is not connected. The device displays the information that the battery charge is sufficient only for 180sec of treatment (with max power) and recommend to connect the power supply.

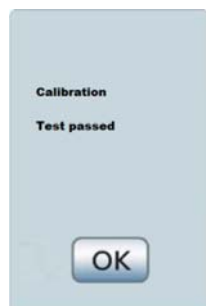

The calibration check was successfully performed. Confirmation via 'OK'.

6 Indications, contraindications and medical precautions

6.1 Indications

Compared to conventional dental surgery, treatment with the SIROLaser Blue offers the following advantages: less invasive, minimum cell destruction, less bleeding, better coagulation, and negligible post-operative edema. Treatment with the laser is low-pain and not pain-free. We recommend using anesthetics if necessary. The SIROLaser Blue may be operated only by trained and qualified personnel.

6.2 List of preset indications

Application	Used wavelenght [nm]	Power	Modus	Duty Cycle [%]	Frequenz [Hz]	Time [s]	Fiber	Help Menu
Surgery								
Abscess	445	2,0W	CW				320µm	Point directly with fiber towards the tissue where the drainage canal is planned. Start laser and perform the drainage. Caution: Avoid bone contact during treatment!
Epulis	445	2,0W	CW				320µm	Stretch the tissue and use laser tip like an scalpel to excise the tissue.
Fibroma	445	2,0W	CW				320µm	Stretch the tissue and use laser tip like an scalpel to excise the tissue. Depending on the size of the fibroma energy can be adjusted until desired cutting is achieved.
Frenectomy	445	2,0W	CW				320µm	Stretch the frenulum and stay in contact with the fiber. Use brush stroke at the base to cut through fibrous attachment. Caution: For the tongue, protect the salivary glands! Avoid bone contact during treatment!
Gingivectomy	445	2,0W	CW				320µm	Gently remove the gingival tissue in contact with the fiber. Caution: Work in parallel to the tooth surface!
Gingivoplastic	445	2,0W	CW				320µm	Gently shape the gingival tissue in contact with the fiber. Caution: Work parallel to the tooth surface!
Implant Uncovery	445	2,0W	CW				320µm	Stretch the tissue and use laser tip like an scalpel to excise the tissue. Caution: Avoid contact to implant and bone!
Incisions/ Excisions	445	2,0W	CW				320µm	Stretch the tissue and use laser tip like an scalpel to incise/excise the tissue.
Operculectomy	445	2,0W	CW				320µm	Stretch the tissue and use laser tip like an scalpel to excise the tissue.

Application	Used wavel length [nm]	Power	Mo- dus	Duty Cycle [%]	Fre- quenz y [Hz]	Time [s]	Fiber	Help Menu
Gingival Troughing	445	2,0W	CW				320µm	Gently shape the gingival tissue in contact with the fiber. Caution: Work parallel to the tooth surface!
Periodontology								
Periimplantitis (Germ Reduction)	970	1,5W	PF	50	12		320µm	Move the fiber tip around the implant gently up and down with a sinuous movement, covering the wall of the tissue. Caution: Keep the laser tip always in motion!
Perio. Germ Reduction	970	1,5W	PF	50	10		320µm	Irradiate the whole pocket starting from the deepest position using a meandering course to cover all contaminated regions. Reduce power, if pain sensations appear.
Endodontics								
Endo. Germ Reduction	970	1,5W	PF	50	15		200µm Endo	Carefully insert the fiber into the root canal, ca. 1 mm from the apex, start laser and retract fiber slowly in circular motion from the canal (1-2 mm/s). Repeat procedure 4 times in 5-seconds-intervals. Caution: Do not stay at the apex after laser activation!
Pulpotomy	970	2,0W	PF	65	5		200µm Endo	After conventional pulp removal, residual pulp tissue can be removed with the laser.
Gangrene Germ Reduction	970	2,0W	PF	65	20		200µm Endo	Carefully insert the fiber into the root canal, directly to the apex, start laser and after maximum 2 seconds at the apex, retract fiber slowly in circular motion from the canal (1-2 mm/s). Repeat procedure 4 times in 5-seconds-intervals. Caution: Stay maximum 2 seconds at the apex after laser activation!
Soft Laser Therapy								
Burning mouth- syndrome	660	50mW	CW			10	8mm (rod)	Move the light guide back and forth over the area being treated so that the entire affected region is covered. Use the power settings provided for this application.
Dentin hypersensitivity	660	25mW	CW			160	8mm (rod)	Move the light guide back and forth over the whole dentine surface so that the entire affected region is covered. Use the power settings provided for this application.
Wound healing	660	25mW	CW			120	8mm (rod)	Move the light guide back and forth over the area being treated so that the entire affected region is covered. Use the power settings provided for this application.

Application	Used wavel ength [nm]	Power	Mo- dus	Duty Cycle [%]	Fre- quenz y [Hz]	Time [s]	Fiber	Help Menu
Miscellaneous								
Haemostasis	445	2,0W	CW				320µm	Stop the blood flow by moving the tip of the laser over the affected tissue surface with opened blood vessels. Avoid bone contact during treatment!
Aphthous Ulcers	970	2,0W	PF	50	10		320µm	Anesthetics not needed! Apply laser 1-3 mm away from lesion for a few seconds - semicontact, wave the laser fiber over the entire lesion. Interrupt treatment briefly, if pain sensations occurs.
Desensitization	970	1,0W	CW				320µm	Apply tin fluoride solution as described in scientific diode-laser studies on the sensitive tooth areas, apply laser 2-4 mm away from these regions - semicontact, total time per area: 60 seconds. Caution: Avoid contact to dentine, keep laser tip always in motion!
Herpes	970	2,0W	PF	50	10		320µm	Anesthetics not needed! Apply laser 1-3 mm away from lesion for a few seconds - semicontact, wave the laser fiber over the entire lesion. Interrupt treatment briefly, if pain sensations occurs.

6.3 Further non-preset indications

Further non-preset applications which you may define individually and medicate according to scientific publications in My Applications:

- Frenotomy
- Biopsy
- Laser assisted flap surgery
- Incisions and draining of abscesses
- Papillectomy
- Vestibuloplasty
- Excision of lesions
- Excision of hyperplasias
- Leukoplakia
- Crown lengthening
- Set hidden teeth free

6.4 Examples of treatment risk

Surgery area

Risk: Soft and hard tissue necrosis or overheating of the tooth.

Countermeasure: Use the laser beam like a scalpel, holding it perpendicular to the surface under treatment, and never aim it at a single point for a longer period of time. Do not select excessively high power levels for the laser.

WARNING

Never treat perpendicular to any bone surface.

Endodontics area

Root canal germ reduction

Risk: Contractions in the apical region, small fusions and microfractures.

Countermeasure: Measure the depth and stop 1 mm above the root apex. Never aim the optical fiber at a single point in the root apex for a longer period of time. The optical fiber must be moved constantly during treatment. Start in the apical region and work your way up to the crown.

Gangrenous canals

Risk: Contraction, fusion and bone necrosis.

Countermeasure: Measure the depth and stop 1 mm above the root apex. Never aim the optical fiber at a single point in the root apex for a longer period of time. The optical fiber must be moved constantly during treatment. Start in the apical region and work your way up to the crown.

Periodontics area

Risk: Minor necrosis or scarring of the radicular area.

Countermeasure: When working in periodontal pockets, always aim the laser parallel to, i.e. never perpendicular to, the roots. Run the distal end of the optical fiber over the entire inner surface of the periodontal pocket.

6.5 Contraindications

All clinical procedures performed with the SIROLaser Blue must be subjected to the same clinical judgment and care as with traditional techniques. Patient risk must always be considered and fully understood before clinical treatment. The clinician must completely understand the patient's medical history prior to treatment. Exercise caution for general medical conditions that might contraindicate a local procedure. Such conditions may include allergy to local or topical anesthetics, cancer, pregnancy, heart disease, lung disease, bleeding disorders, sleep apnea, and immune system deficiency, or any medical conditions or medications that may contraindicate use of certain light/laser type sources associated with this device. Medical clearance from patient's physician is advisable when doubt exists regarding treatment.

Moreover, patients suffering from photodermatoses must not be treated as well as photosensitized patients (Photoallergy).

7 Cleaning, disinfection and sterilization

Following treatment, switch off the SIROLaser Blue and disconnect the power cable from the power supply.

NOTICE

When following these instructions wear gloves.

Control unit, handpiece body, handpiece tube and foot control are supposed to be cleaned and wipe-disinfected.

Dispose the single use fiber tips.

The removable stainless steel handpiece sleeve, therapy light guides, fibercutter and bending tool are supposed to be cleaned and sterilized.

CAUTION

Do not clean and disinfect the parts using a washer-disinfector! The parts may be seriously damaged.

For the number of sterilization cycles, see chapter "Replacement of parts subject to wear and tear [→ 69]".

7.1 Cleaning

NOTICE

Manual cleaning must always be combined with disinfection.

Handpiece sleeve

1. Remove the handpiece sleeve from the handpiece body by pressing the snap tab after disposing the single-use fiber tip or the therapy light guide.

CAUTION

Danger of damage to the optical system

Reattach the protective cap to the optical system of the handpiece immediately after dismantling the EasyTip or MultiTip. Do this before taking any hygienic measures.

2. Clean the handpiece sleeve with a suitable brush under running water.

Therapy light guide (MultiTip)

- Clean the therapy light guide under running water (< 38 °C, water must be at least drinking water quality).

NOTICE

Never clean in an ultrasonic bath!

Fibercutter

- Clean the fiber cutter in the ultrasonic bath or with a suitable brush under running water (< 38 °C, water must be at least drinking water quality).

Laser protective goggles

- Before cleaning the laser protective goggles, please read and observe the instructions for use provided by the manufacturer and attached to the goggles in the case.

7.2 Disinfection

Disinfect the upper mentioned parts by wipe disinfection:

SIROLaser Blue (wipe disinfection only)

NOTICE

Use only disinfectants that comply with the requirements of your national authorities and whose bactericidal, fungicidal and virucidal properties have been tested and properly certified.

Sirona recommends the use of MinuteWipes from Alpro. In the USA: Caviwipes™.

Observe the instructions provided by the manufacturers of these disinfectants.

7.3 Sterilization

WARNING

Therapy light guide (MultiTip), handpiece sleeve, fibercutter and bending tool must be sterilized prior to initial use and before each subsequent use.

WARNING

Single-use fiber tips (EasyTip) must not be sterilized again after usage. They are disposable products.

NOTICE

Remove any possible water residues.

The parts must be sterilized only in an autoclave with saturated water vapor at minimum sterilization values of 135 °C (275 °F), 3 min. holding time and 2.04 bar (29,59 psi) overpressure.

Steam sterilizers are approved for sterilization that fulfill the requirements of EN 13060 class B or validated steam sterilizer (EN 13060 class S) which are employing three, separate initial vacuum air-purges being suitable for the sterilization of dental handpieces. For example SIRONA DAC PROFESSIONAL or DAC PREMIUM.

NOTICE

Sterilize the therapy light guides in a packing material suitable for sterilization and storage to prevent scratching or chipping the light guides in the autoclave. Do not exceed a temperature of 140 °C (284 °F) during the drying cycle. Do not abort the drying cycle before it has ended. Do not try to accelerate the cool-down process by placing the MultiTips in cold water. This could cause the therapy light guide to crack.

CAUTION

Store all components so that they are protected against contamination. Sterilize again once the storage period has elapsed.

7.4 Cleaning the control unit

Use a dry, soft cloth to remove dust from the SIROLaser Blue. More stubborn spots can be removed with a damp cloth.

NOTICE

Please proceed carefully not to scratch and damage the foil on the touch screen.

You can wipe-disinfect the SIROLaser Blue using any of the products that are commonly used to disinfect medical electrical equipment, e.g. MinuteWipes, Caviwipes.

CAUTION

Spray disinfection may allow liquids to penetrate into the SIROLaser Blue!

The SIROLaser Blue may be disinfected **only by wiping** it. Do never spraydisinfect the SIROLaser Blue.

Observe the instructions provided by the manufacturers of these disinfectants.

MinuteWipes Fa. Alpro.

In USA: Caviwipes™.

8 Maintenance and service

8.1 Safety checks

The following safety checks must be performed every 24 months by a qualified service engineer:

- Visual inspection of the unit and its accessories for mechanical damage that might impair operation
- General function check
- Check of the visual and audible indicators
- NC and SFC earth leakage current acc. to IEC 60601
- NC and SFC housing leakage current acc. to IEC 60601
- NC and SFC patient leakage current acc. to IEC 60601
- Laser power measurement with a calibrated measuring instrument in the range between 0.2 W and 3 W

8.2 Maintenance

The SIROLaser Blue does not require special maintenance. In case of malfunctioning, see chapter Technical support, repair and testing. However, Sirona Dental Systems GmbH recommends taking the following actions at regular intervals:

Action	Frequency	Conducting personnel
Check of the single-use fiber tips or therapy light guides, see "Assembly of sterile single-use optical fiber tips [→ 28]" and "Assembly of therapy light guides [→ 32]"	Before each treatment session	System owner
Calibration check of the laser, see "Laser calibration check [→ 50]"	Weekly	System owner
Recommended check of the optical power at the end of the single-use fiber tip with an external power meter, see "Laser calibration check [→ 50]"	Every twelve months	System owner
Safety checks (required by law in some European countries)	Every 2 years	Sirona Dental Systems GmbH, local Dental Sales or qualified service engineer.

NOTICE

If national or local legal regulations require additional safety checks for your laser unit, these regulations must be complied with and the corresponding checks must be performed.

The manufacturer accepts responsibility for the safety of the laser unit only if the following requirements are fulfilled:

- Modifications of the laser unit or repair work may be performed only by authorized personnel.
- The electrical installations in the rooms where the SIROLaser Blue is used must fulfill the applicable legal requirements.
- The unit must be used in compliance with the instructions provided in the present manual.

8.3 Troubleshooting of simple defects

In case of malfunctioning, proceed as follows:

General

First general directions in case of malfunctioning:

- Check if power supply is connected properly and/or rechargeable battery is loaded.
- Check if EasyTip or MultiTip is installed correctly.
- Be sure that all operational steps have been carried out correctly.
- Check the functioning of the finger switch and/or wireless foot control by pressing several times.

The touch screen of the SIROLaser Blue remains dark after switching it on.

- Check the connection of the power cable and/or check the rechargeable battery.
- Make sure that the switch on the switching power supply is switched on.
- Check the connection of the interlock device.

Finger switch

The finger switch is claimed to be broken.

- Check if the finger switch is chosen in the settings submenu.
- Check if the plug of the cable is properly connected to the control unit.

Foot control

The foot control is not working or claimed to be missing.

- Check if the foot control is chosen in the settings submenu.
- Check the battery of the wireless foot control.
- Register the wireless foot control again.

Single-use fiber tip or therapy light guide

The single-use fiber tip or therapy light guide is claimed to be missing.

- Make a visual check of the single-use fiber tip or therapy light guide and its connector. If you see any damage (e.g. scratches) replace the single-use fiber tip or therapy light guide with a new one.
- Check the connection of the single-use fiber tip or therapy light guide.
- Check the proper assembly of the handpiece sleeve.

Aiming beam

- Be sure that all operational steps have been carried out correctly.

There is no aiming beam.

- Check to see if the single-use fiber tip or therapy light guide or its connector is damaged. If the single-use fiber tip or therapy light guide is damaged, replace it with a new one.
- Check the connection of the single-use fiber tip or therapy light guide.
- Check the proper assembly of the handpiece sleeve.
- Be sure that all operational steps have been carried out correctly.

The light of the aiming beam does not project a uniform circular pattern.

- Trim the end of the single-use fiber tip with the fiber cutter. Always make the notch perpendicular to the optical fiber.

Interlock

The interlock is claimed to be open.

Interlock is used:

- Check the connection of the interlock.
- Check if the door is open.

Interlock is not being used:

- Check if the interlock bridge is connected properly.

Overheating

The laser source is claimed to overheat.

- Check if all convection openings for air cooling on the sides of the unit are uncovered.
- Check if unit is placed near heat sources. If so, place the unit somewhere else and let it cool down.

Accoustic signal

There is no accoustic signal for activating the laser and/or pushing the buttons.

- Check the settings for the accoustic signals in the settings submenu.

If you cannot solve the malfunctioning, switch off the laser and contact Sirona Dental Systems GmbH, your local dental dealer or your authorized service center.

8.4 Technical support, repair and testing

Sirona provides technical information on the repair of individual components only to authorized dealers and only after conducting an advanced training course for their technical personnel. Please contact your local dental dealer or an authorized Customer Service Department for technical support.

The SIROLaser Blue may be sent in for repair or for safety inspection only in its original packaging, including all accessories. Disinfect the SIROLaser Blue and sterilize the accessories according to the relevant instructions for use before shipping them.

8.5 Replacing the rechargeable battery of the control unit

If the rechargeable battery does not load more than 30% even by charging it overnight, the battery should be replaced.

1. Disconnect the power supply.
2. Take the handpiece out of the holder and unwind the tube completely.
3. Remove the battery cover.
4. Pull out the battery with the strips applied to the battery.
5. Mount the new battery.
6. Closing the battery cover. Make sure that the small metal cylinder of the cable is properly placed in the anti-pull protection! Otherwise, the handpiece is damaged.

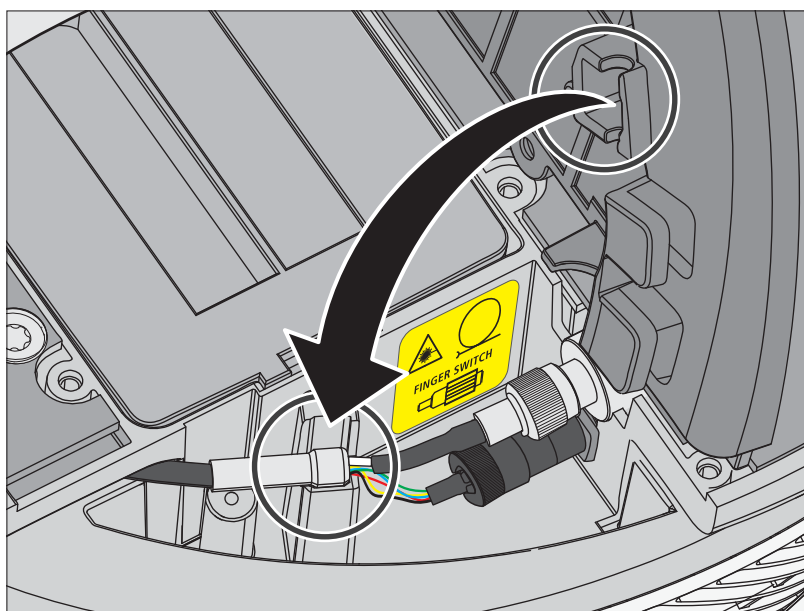
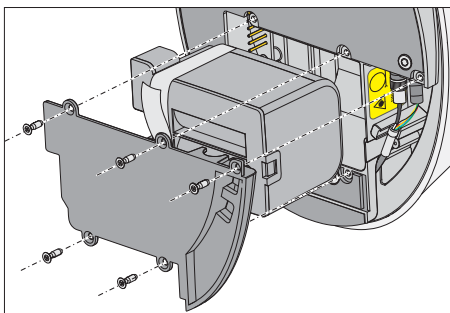

7. Switch on the laser (use power supply if necessary).
8. Choose "Battery calibration" in the settings menu.
 - ↳ The following message will appear: "Unplug the laser and press OK for battery calibration. For further steps refer to user manual."
9. Unplug laser and press 'OK'.
 - ↳ The battery will now discharged automatically until the device switches off due to lack of power.
10. Plug in the power supply, switch on the laser device and charge the battery for at least 2 h (best over night).

For perfect battery performance a battery calibration must be proceeded in any case of having removed and again mounted or completely replaced the battery pack, see chapter "Battery calibration [→ 49]".

⚠ CAUTION

Make sure that the small metal cylinder of the cable is properly placed in the anti-pull protection. Fiber in cable may break if not correctly mounted resulting in high repair costs.

Only use the Sirona Dental Systems battery pack, see "Spare parts [→ 26]".

8.6 Replacing the batteries of the wireless foot control

The wireless foot control is powered by two (2) AAA batteries (commercially available).

When the battery is empty, select the finger switch in the settings submenu "Activation device [→ 46]" for further operation of the SIROLaser Blue.

The batteries can be changed by the user.

The housing of the wireless foot control must be opened to change the battery. Touch a grounded metal part before opening the housing to prevent damage to the PC board due to electrostatic discharge.

⚠ CAUTION

Prior to changing the batteries, switch the SIROLaser Blue off at the main switch. This prevents accidental triggering.

Removing and replacing the batteries

1. Remove the screws from the bottom of the foot control.
2. Remove the cover and open the battery compartment.
3. Pull the battery holder out of the battery compartment and replace the batteries with new ones. Be careful to insert them with the correct polarity (minus pole facing spring).

Assembling the foot control

1. Place the battery holder back again in the battery compartment.
2. Close the battery compartment with the cover.
3. Screw tight the screws at the bottom of the foot control.

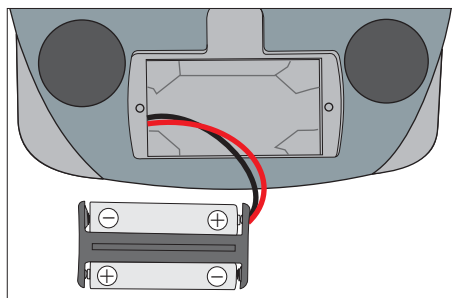
**NOTICE**

After changing the batteries, start the SIROLaser Blue and check the complete functionality of the foot control. In case the finger switch was selected as preliminary activation device it is necessary to re-select the wireless foot control. It is not necessary to reregister the foot control again at the SIROLaser Blue after changing batteries.

8.7 Replacement of parts subject to wear and tear

Check the following parts subject to wear and tear and replace where applicable:

- Therapy light guides (change after 2,000 sterilization cycles or every two years)
- Silicone key pad of the handpiece (change after 400 treatments/sterilizations)
- Fiber cutter (change after 400 treatments/sterilizations or every two years)
- Rechargeable battery (change after 1000 charging cycles or every two years)
- Batteries in wireless foot control (change after 1 year)

For further informations, see chapter "Cleaning, disinfection and sterilization [→ 61]".

CAUTION

Only use parts from Sirona Dental Systems, see "Spare parts [→ 26]".

9 Electromagnetic compatibility

NOTICE

The SIROLaser Blue complies with all requirements for electromagnetic compatibility according to IEC 60601-1-2: 2007

Definitions:

Emission (electromagnetic)

When electromagnetic energy is emitted by a source.

Interference immunity

The ability of a device or system to work without errors even if there is electromagnetic interference.

Immunity level

The maximum level of a certain electromagnetic interference that affects a particular device or system, where the device or system remains operative with a certain level of performance.

9.1 Electromagnetic emission

The **UNIT** is intended for operation in the electromagnetic environment specified below.

The customer or user of the **UNIT** should make sure that it is used in such an environment.

Emission measurement	Conformity	Electromagnetic environment - guidelines
RF emissions according to CISPR 11	Group 1	The UNIT uses RF energy only for its internal function. Therefore, its RF emissions are very low and are not likely to cause any interference in nearby electronic equipment.
RF emissions according to CISPR 11	Class B	The UNIT is intended for use in all facilities, including residential areas and in any facilities connected directly to a public power supply providing electricity to buildings used for residential purposes.
Harmonics according to IEC 61000-3-2	Class A	
Voltage fluctuations / flicker according to IEC 61000-3-3	coincides	

9.2 Interference immunity

The **UNIT** is intended for operation in the electromagnetic environment specified below.

The customer or user of the **UNIT** should make sure that it is used in such an environment.

Interference immunity tests	IEC 60601-1-2 test level	Compliance level	Electromagnetic environment – guidance
Electrostatic discharge (ESD) according to IEC 61000-4-2	± 6 kV contact discharge ± 8 kV air discharge	± 6 kV contact discharge ± 8 kV air discharge	Floors should be wood, concrete, or ceramic tile. If floors are covered with synthetic material, the relative humidity should be at least 30 %.
Electrical fast transient/burst according to IEC 61000-4-4	± 1 kV for input and output lines ± 2 kV for power supply lines	± 1 kV for input and output lines ± 2 kV for power supply lines	The quality of the line power supply should be that of a typical commercial or hospital environment.
Surge voltages according to IEC 61000-4-5	± 1 kV differential mode ± 2 kV common mode voltage	± 1 kV differential mode ± 2 kV common mode voltage	The quality of the line power supply should be that of a typical commercial or hospital environment.
Voltage dips, short interruptions and variations of the power supply according to IEC 61000-4-11	<5% U_T for ½ period (>95% dip of U_T) 40% U_T for 5 periods (60% dip of U_T) 70 % U_T for 25 periods (30% dip of U_T) <5% U_T for 5sec. (>95% dip of U_T)	<5% U_T for ½ period (>95% dip of U_T) 40% U_T for 5 periods (60% dip of U_T) 70 % U_T for 25 periods (30% dip of U_T) <5% U_T for 5sec. (>95% dip of U_T)	The quality of the line power supply should be that of a typical commercial or hospital environment. If the user of the UNIT requires it to continue functioning following interruptions of the power supply, it is recommended to have the UNIT powered by an uninterruptible power supply or a battery.
Magnetic field of power frequencies (50/60 Hz) according to IEC 61000-4-8	3 A/m	3 A/m	Power frequency magnetic fields should be at levels characteristic of a typical location in a typical commercial or hospital environment.
Remarks: U_T is the AC supply voltage prior to application of the test level.			
			Portable and mobile radio equipment must not be used within the recommended working clearance from the UNIT and its cables, which is calculated based on the equation suitable for the relevant transmission frequency. Recommended working clearance:

Interference immunity tests	IEC 60601-1-2 test level	Compliance level	Electromagnetic environment – guidance
Conducted RF interference IEC 61000-4-6	3 V _{eff} 150 kHz to 80 MHz ¹	3 V _{eff}	$\bar{d} = [1.2] \sqrt{P}$
Radiated RF interference IEC 61000-4-3	3 V/m 80 MHz to 800 MHz ¹ 3 V/m 800 MHz to 2.5 GHz ¹	3 V _{eff} 3 V _{eff}	$\bar{d} = [1.2] \sqrt{P}$ at 80 MHz to 800 MHz $\bar{d} = [2.3] \sqrt{P}$ at 800 MHz to 2.5 GHz <p>where P is the nominal transmitter output in watts (W) specified by the transmitter manufacturer and \bar{d} is the recommended working clearance in meters (m).</p> <p>Field strengths from fixed RF transmitters, as determined by an electromagnetic site survey² should be less than the compliance level³ in each frequency range.</p> <p>Interference is possible in the vicinity of equipment bearing the following</p>  <p>graphic symbol.</p>

1. The higher frequency range applies at 80 MHz and 800 MHz.
2. Field strengths from fixed transmitters, such as base stations for radio (cellular/cordless) telephones and land mobile radios, amateur radio, AM and FM radio broadcast and TV broadcast, cannot be predicted theoretically with accuracy. An investigation of the location is recommended to determine the electromagnetic environment resulting from stationary HF transmitters. If the measured field strength in the location in which the **UNIT** is used exceeds the applicable RF compliance level above, the **UNIT** should be observed to verify normal operation. If unusual performance characteristics are observed, it may be necessary to take additional measures such as reorientation or repositioning of the **UNIT**.
3. Over the frequency range 150kHz to 80MHz, field strengths should be less than 3V/m.

9.3 Working clearances

Recommended working clearances between portable and mobile HF communication devices and the UNIT

The **UNIT** is intended for operation in an electromagnetic environment, where radiated RF interference is checked. The customer or the user of the **UNIT** can help prevent electromagnetic interference by maintaining a minimum distance between portable and mobile RF communications equipment (transmitters) and the **UNIT** - depending on the maximum output power of the communication device, as shown below.

Power rating of the transmitter [W]	Working clearance according to transmission frequency [m]		
	150 kHz - 80 MHz	80 MHz - 800 MHz	800 MHz - 2.5 GHz
	$d = [1, 2] \sqrt{P}$	$d = [1, 2] \sqrt{P}$	$d = [2, 3] \sqrt{P}$
0.01	0.12	0.12	0.23
0.1	0.38	0.38	0.73
1	1.2	1.2	2.3
10	3.8	3.8	7.3
100	12	12	23

The recommended safety distance d in meters (m) can be determined for transmitters, whose maximum power rating is not specified in the above table, using the equation that belongs to the corresponding column, wherein P is the maximum power rating of the transmitter in watts (W) according to the transmitter manufacturer.

Note 1

The higher frequency range applies at 80 MHz and 800 MHz.

Note 2

These guidelines may not apply in all cases. The propagation of electromagnetic waves is influenced by their absorption and reflection by buildings, objects and persons.

10 Disposal



Based on Directive 2012/19/EU and country-specific disposal directives for waste electrical and electronic equipment, we would like to point out that these must be disposed of in a special way within the European Union (EU). These regulations require environmentally compliant recycling/disposal of waste electrical and electronic equipment. They must not be disposed of as domestic waste. This is shown with the symbol of the crossed out dust bin, which has been in use since March 24, 2006.

Disposal procedure

We feel responsible for our products from the initial idea to their disposal. That is why we give you the option of taking back our waste electrical and electronic equipment.

If disposal is required, please proceed as follows:

In Germany

In order to arrange return of the electrical equipment, please send a disposal request to "enretec GmbH." The following options are available for this purpose:

- On the homepage of enretec GmbH, click on the "Return of electronic equipment" button under the "eom" menu item.
- Alternatively, you may also contact the company directly.

enretec GmbH
Kanalstraße 17
16727 Velten

Tel: +49 3304 3919-500
Email: eom@enretec.de

As manufacturers, we assume the costs for disposal of waste from electrical and electronic equipment in accordance with the country-specific disposal regulations (ElektroG). All disassembly, transport and packaging costs are to be borne by the owner/operator.

Proper preparation (cleaning/disinfection/sterilization) of the equipment must be carried out prior to disassembly/disposal.

Any nonpermanently installed equipment will be picked up at its installation site in the practice. Permanently installed equipment will be picked up curbside at your address by appointment.

Other countries

The dental dealers would be glad to provide you with country-specific information.



10.1 Batteries

Please dispose the batteries according to the disposal regulations and legal requirements applicable in your country.

Prior to disposal, remove the following batteries:

- Batteries in the wireless foot control
- Lithium battery in the SIROLaser Blue

10.2 Accessories

MultiTips, handpiece sleeve incl. keypad for finger switch, bending tool for EasyTips and fiber cutter may be disposed in the domestic refuse. Please disinfect or sterilize the parts prior to disposal.

Please dispose the single-use fiber tips (EasyTips) in a biohazard medical waste/ sharps container.

11 Appendix

11.1 Appendix A – Certification

The unit is manufactured in compliance with the provisions of Council Directive 93/42/EEC concerning medical devices.

11.2 Appendix B -Label positions

11.2.1 Control unit

The following figures show the positions of the labels on the SIROLaser Blue:

Front side

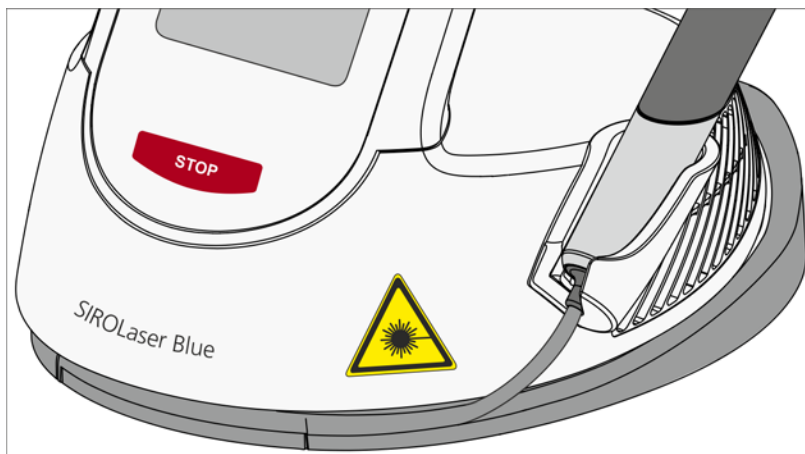

Rear side

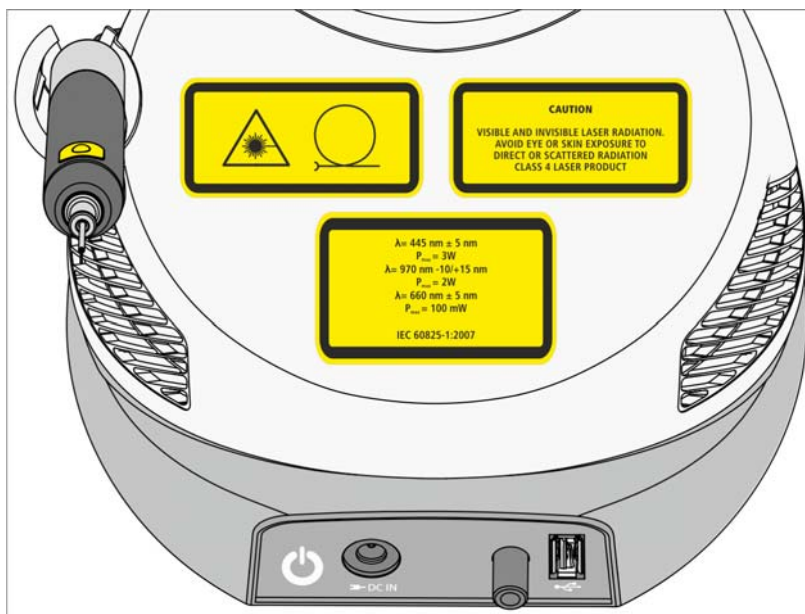

Bottom side

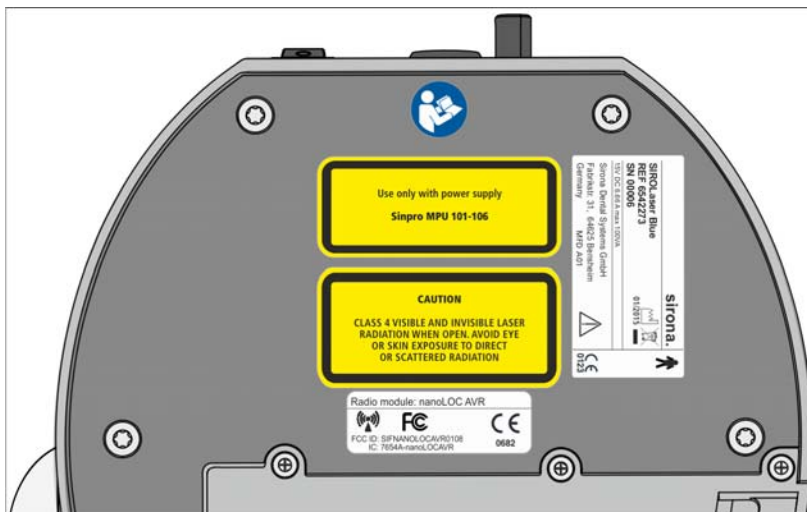

Under the battery cover

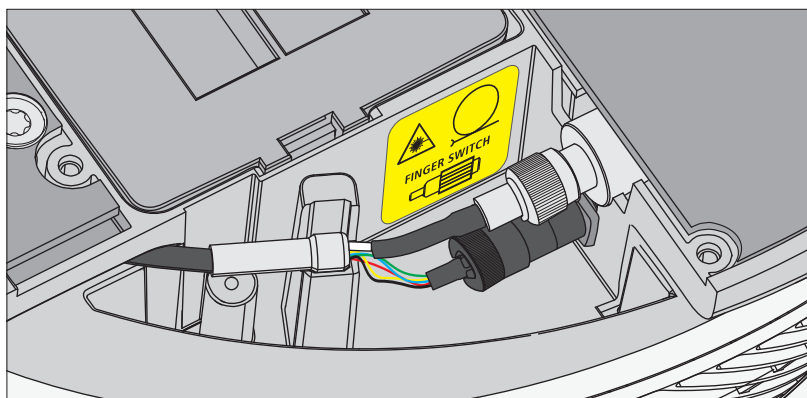

11.2.2 Wireless foot control – optional

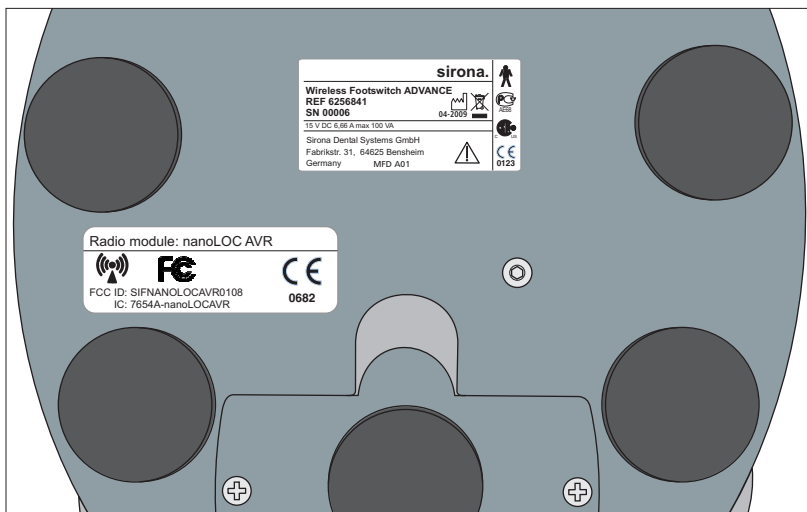

11.3 Appendix C – Safety circuit (interlock)

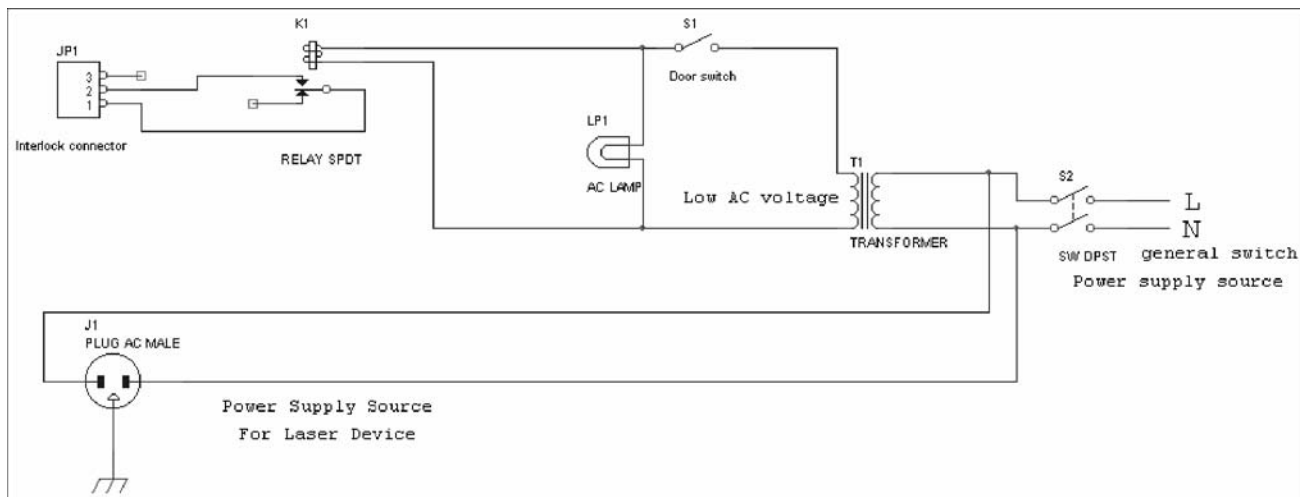

JP1	Interlock connection supplied with the SIROLaser Blue (Insulate the jumper between pins 1 and 2; connect both of these pins to relay K1 with a two-core cable).
K1	Low-level relay (AC)
Door switch S1	Must close the interlock circuit when the treatment room door is closed.
Lp1	Optional low-level lamp used as an optical warning while the laser is in operation.
T1	Power transformer
S2	Main switch for power supply
J1	Possible power supply for the SIROLaser Blue

⚠ CAUTION

It is recommended to keep the distance between connector JP1 and relay K1 as short as possible.

Units designed for this purpose are already available from various companies, however, are also unreasonably expensive in some cases. We recommend having the installation performed by a qualified electrician who is also responsible for the electrical system.

We reserve the right to make any alterations which may be required due to technical improvements.

© Sirona Dental Systems GmbH 2015
D3648.201.01.02.02 10.2015

Sprache: englisch
A.-Nr.: 121 247

Printed in Germany

Sirona Dental Systems GmbH

Fabrikstraße 31
D-64625 Bensheim
Germany
www.sirona.com

in the USA:

Sirona Dental Systems LLC
4835 Sirona Drive, Suite 100
Charlotte, NC 28273
USA

Order No

65 40 863 D3648